

GYROSCOPE Robot

6

modèles • models
modelen • Modelle
Modelos
Modelli

134

Pièces / Parts
Teile / Stukken
Elementos
Pezzi

Gyroskop-Roboter
Robot cu Giroscop

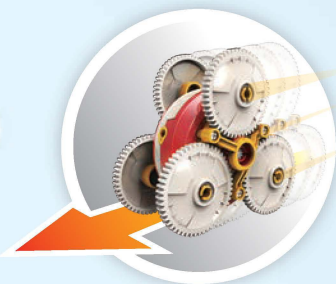

8+

DÉFIE LA GRAVITÉ • DEFY GRAVITY
SCHLAG DER SCHWERKRAFT
EIN SCHNIPPCHEN TROTSEER DE ZWAARTEKRACHT
DESAFÍA LA GRAVEDAD • SFIDA LA FORZA DI GRAVITÀ

Buki
France

Continut

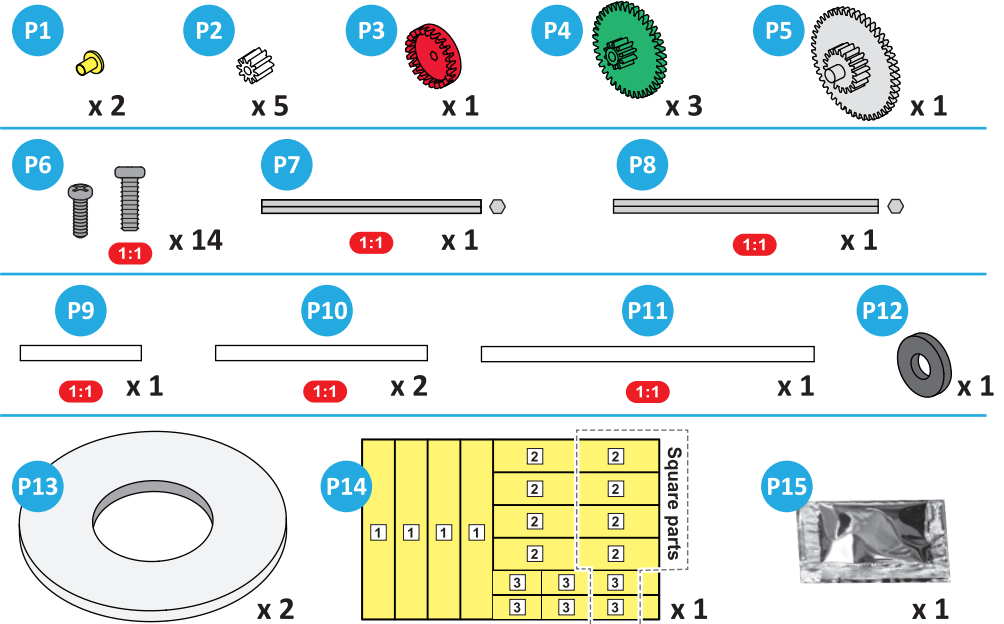

<p>P1: Eyeillet P2: Engrenage (Blanc) P3: Engrenage (Rouge) P4: Engrenage (Vert) P5: Grand engrenage (Blanc) P6: Vis P7: Barre hexagonale (S) P8: Barre hexagonale (L) P9: Barre ronde (S) P10: Barre ronde (M) P11: Barre ronde (L) P12 – Joint P13 – Rondelle P14 – Revêtement P15 – Huile (manipuler avec soin)</p>	<p>P1: Eyelet P2: Pinion gear (white) P3: Gear (red) P4: Gear (green) P5: Large gear (white) P6: Screws P7: Hex shaft (S) P8: Hex shaft (L) P9: Round shaft (S) P10: Round shaft (M) P11: Round shaft (L) P12: Sponge seal P13 – Washer P14 – Sponge P15 – Oil (handle with care)</p>	<p>P1: Öse P2: Zahnrad (weiß) P3: Zahnrad (rot) P4: Zahnrad (grün) P5: großes Zahnrad (weiß) P6: Schraube P7: Sechskantstab (S) P8: Sechskantstab (L) P9: Rundstab (S) P10: Rundstab (M) P11: Rundstab (L) P12: Federscheibe P13 – Unterlegscheibe P14 – Feuerscheibe P15 – Öl (mit Vorsicht handhaben)</p>
<p>P1 : Nituri P2 : Pinioni angrenaj (albi) P3 : Angrenaj (rosu) P4 : Angrenaj (verde) P5 : Angrenaj mare (alb) P6 : Suruburi P7 : Arbore hexagonal (S) P8 : Arbore hexagonal (L) P9 : Arbore rotund (S) P10 : Arbore rotund (M) P11 : Arbore rotund (L) P12 : Garnitura P13 - Saibe P14 - Burete P15 - Ulei (manevrati cu grija)</p>	<p>P1: Ojete P2 : Engranaje (Blanco) P3 : Engranaje (Rojo) P4 : Engranaje (Verde) P5 : Engranaje blanco grande P6: Tornillo P7: Barra hexagonal (corta) P8: Barra hexagonal (larga) P9: Barra redonda (corta) P10: Barra redonda (mediana) P11: Barra redonda (larga) P12: Junta P13 - Arandela P14 - Revestimiento P15 - Aceite (manipular con cuidado)</p>	<p>P1: Passacavi P2: Ingranaggio (Bianco) P3: Ingranaggio (Rosso) P4: Ingranaggio (Verde) P5: Ingranaggio grande (bianco) P6 : Vite P7: Barra esagonale (S) P8: Barra esagonale (L) P9: Barra rotonda (S) P10 : Barra rotonda (M) P11: Barra rotonda (L) P12 – Giunto P13 – Rondella P14 – Rivestimento P15 – Olio (maneggiare con attenzione)</p>

Piese de desprins



Desprindeți piesele la nevoie!

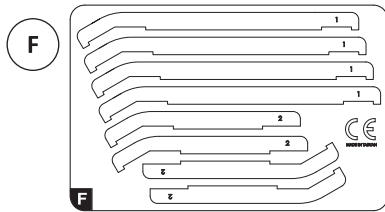
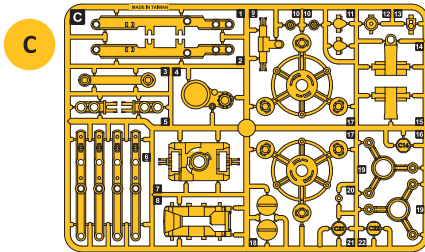
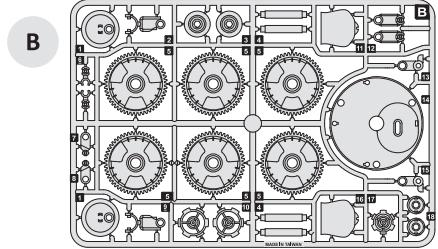
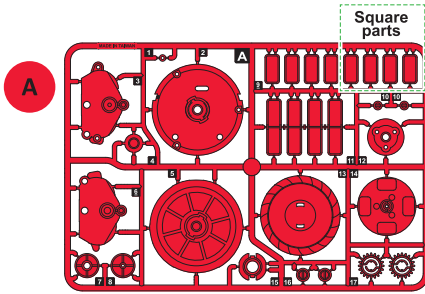

Instrumente suplimentare necesare

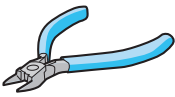

Clește de tăiat



Ciocan

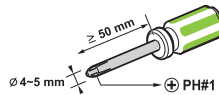

Surubelnita



Pahar gradat



Prosop hartie de bucatarie



Banda adeziva



Betisor de ureche

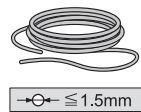

Sfoara

Sfaturi

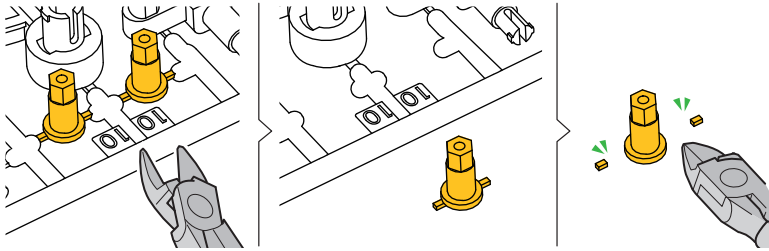

Rugati un adult sa desprinda piesele inainte de a le asambla. La anumite piese, aveti grija sa taiati doar elementele de fixare!

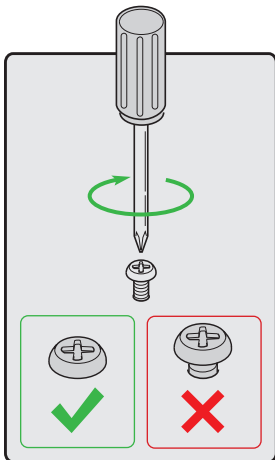

Pentru suruburi folositi surubelnita!

Strangeti surubul complet pentru ca robotul sa poata functiona corect. Pentru a strange suruburile, rotiti surubelnita in sensul acelor de ceasornic.



Cititi cu atentie instructiunile si urmati ordinea pasilor de asamblare!

Ce este un giroscop?

Giroscopul este format dintr-un disc care se rotește în jurul unei axe fixe, susținut de mai multe articulații cardanice (A).

Prin rotirea rapidă a discului central, crești o forță giroscopică ce va menține discul în echilibru.

Putem găsi giroscopie peste tot: smartphone-uri (B), în avioane (C) hoverboard-uri (D).



Cremaliera

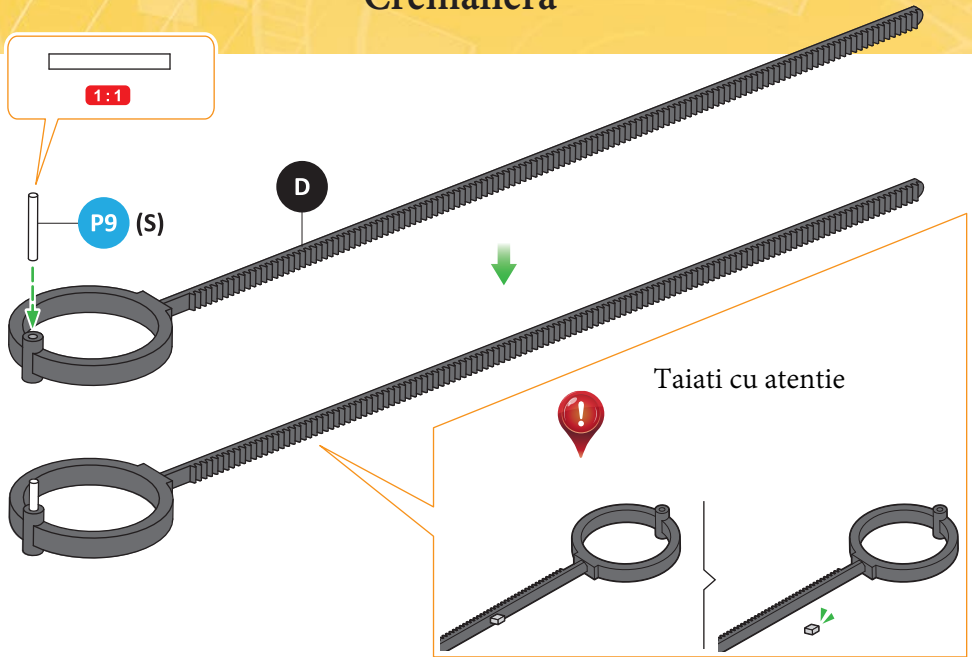

Punte

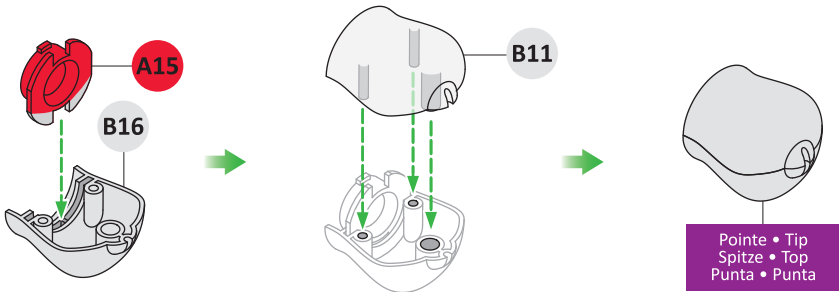

Picior stang

Picior drept

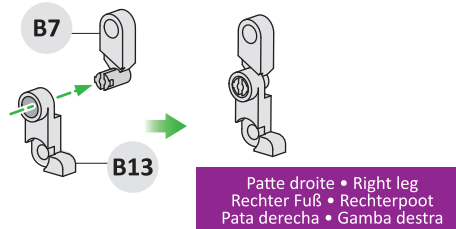
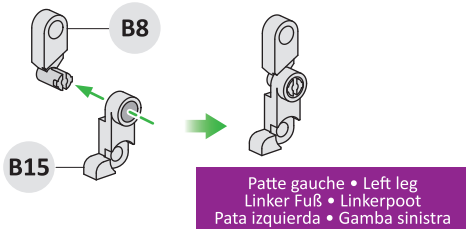

Baza

1



Taiati cu atentie

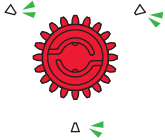

A17

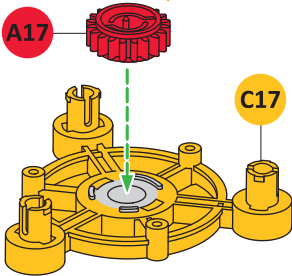

A17

C17

2

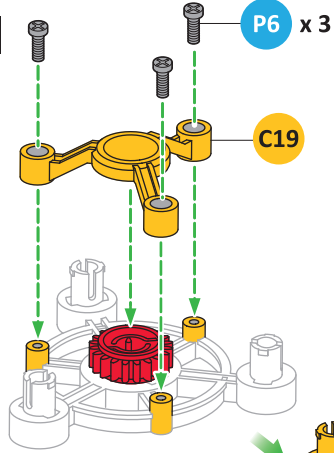

P6 x 3

C19

Baza

Base • Base
Basis • Onderstel
Base • Base

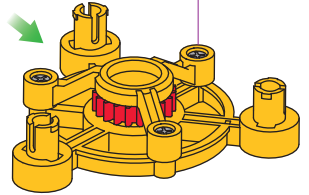

Bratul stang

Bratul drept

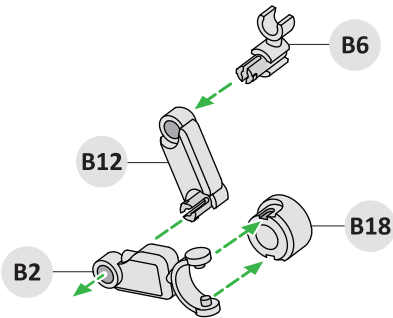

B6

B12

B18

B2

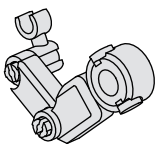

Bras gauche • Left arm
Linker Arm • Linkerarm
Brazo izquierdo • Braccio sinistro

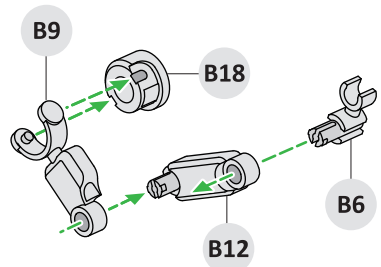

B9

B18

B6

B12

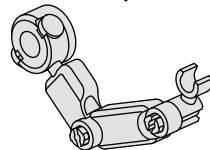

Bras droit • Right arm
Rechter Arm • Rechterarm
Brazo derecho • Braccio destro

Corpul giroscopului

Aplicarea uleiului

Folositi uleiul pentru a va asigura ca piesele se misca fara probleme.



Imaginea de mai jos va arata unde trebuie sa aplicati uleiul. Aplicati-l cu grija!

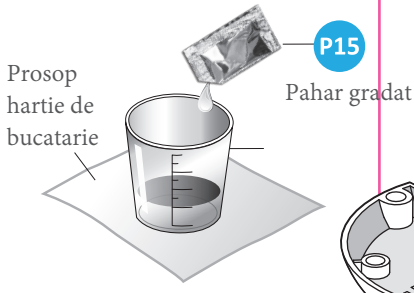

Betisor de ureche

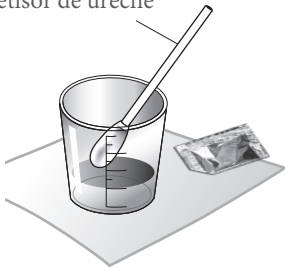

Exemplu:

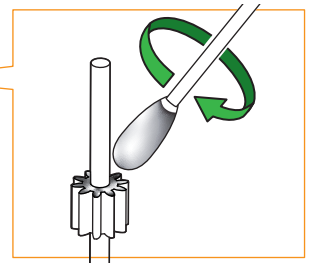
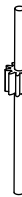
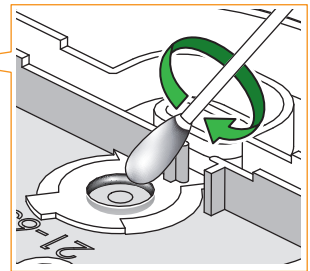
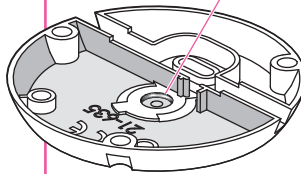

1

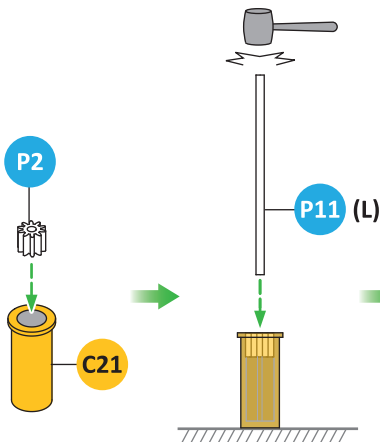

Barre avec engrenage • Shaft with gear
Stange mit Zahnrad • Staaf met raderwerk
Barra con engranaje • Barra con ingranaggio

Arbore cu angrenaj

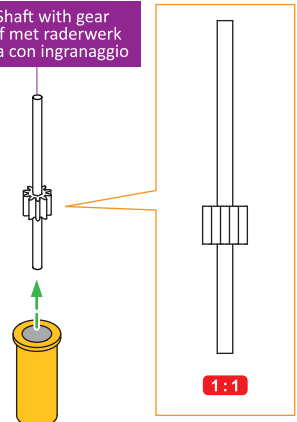

1:1

2

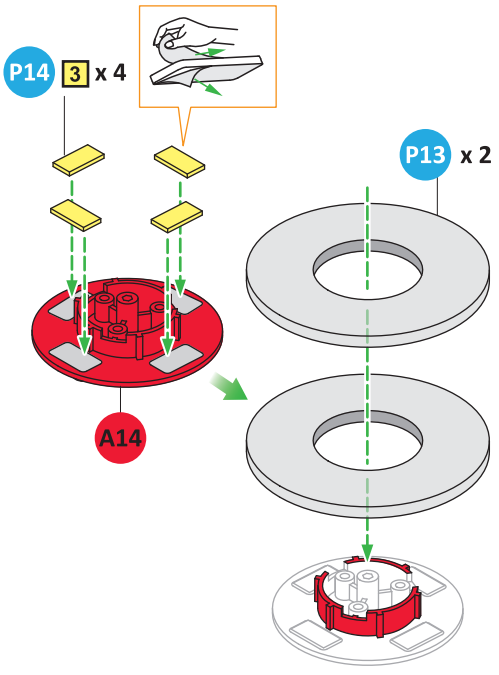
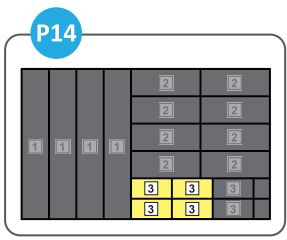

3

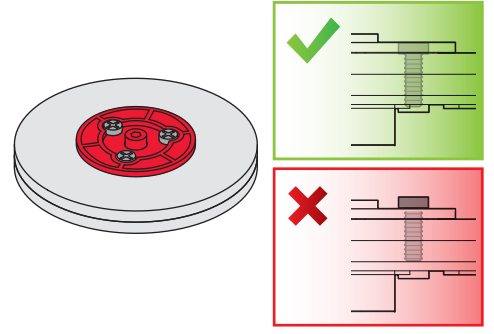
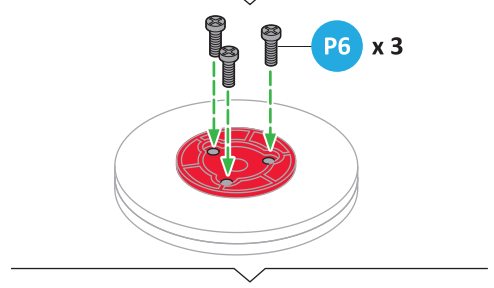
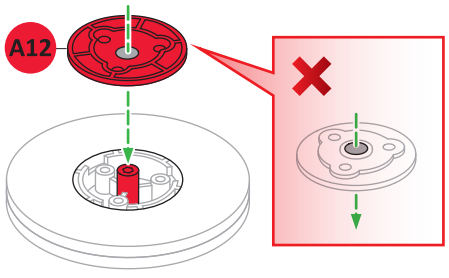

4

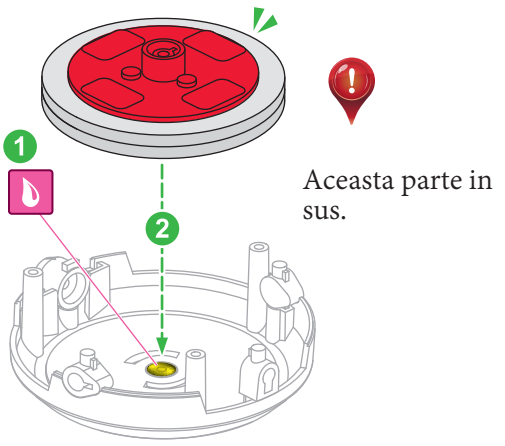
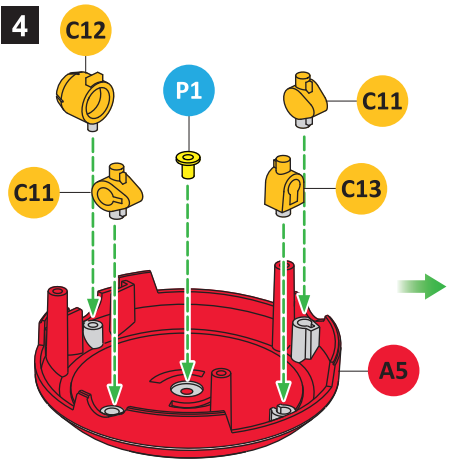

5

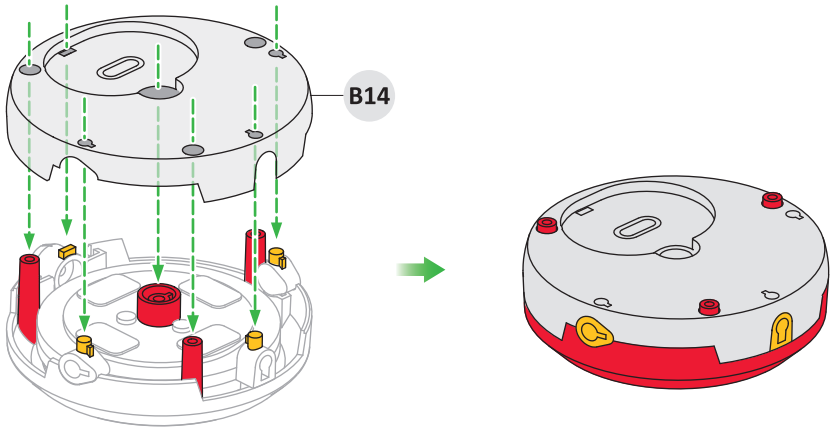

6

Barre avec engrenage
 Shaft with gear
 Stange mit Zahnrad
 Staaaf met raderwerk
 Barra con engranaje
 Barra con ingranaggio

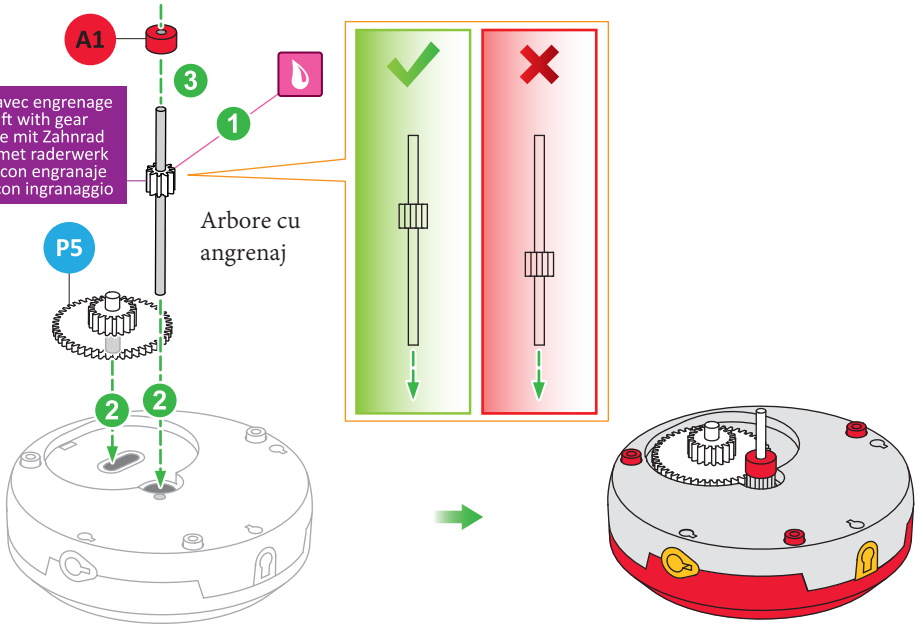

7

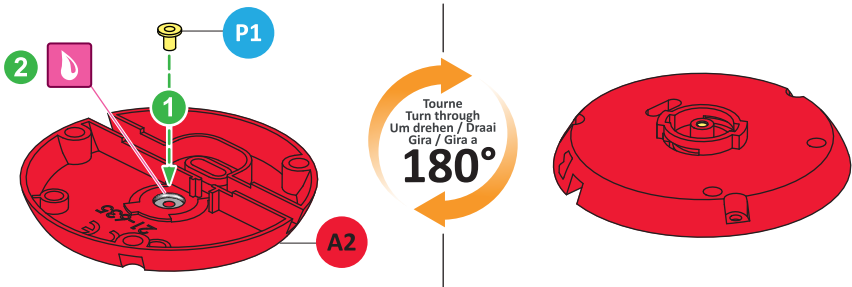

8

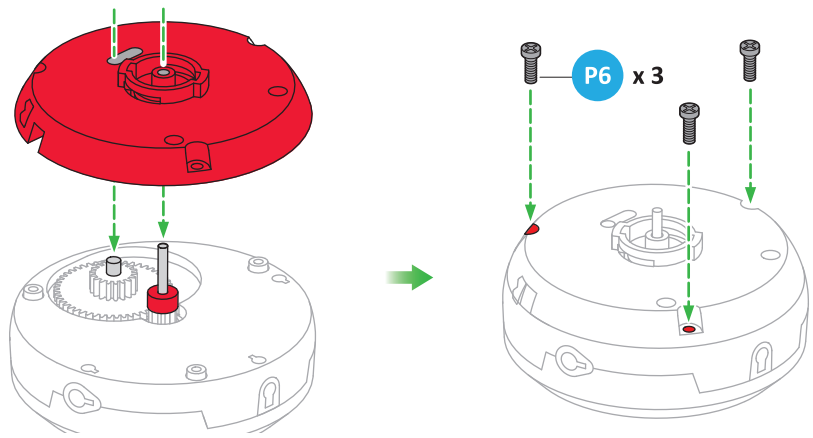

9

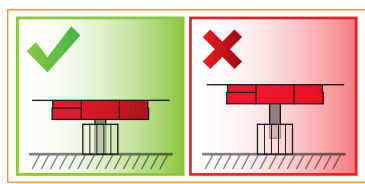
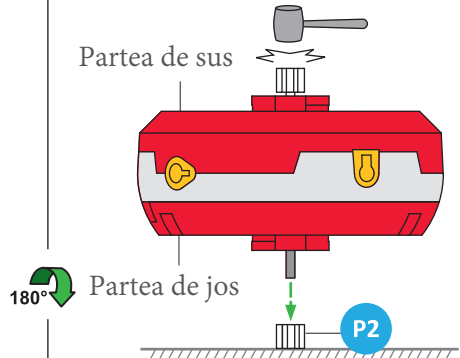
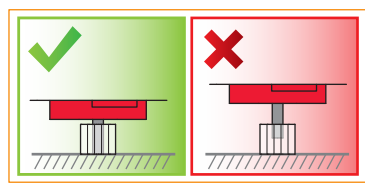
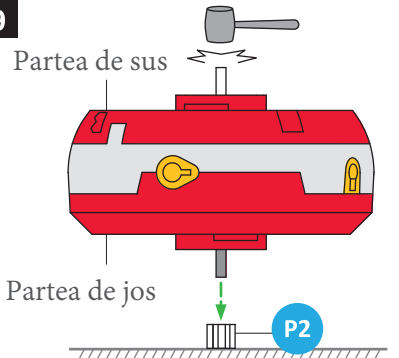

Module • Module
 Modul • Module
 Módulo • Modulo

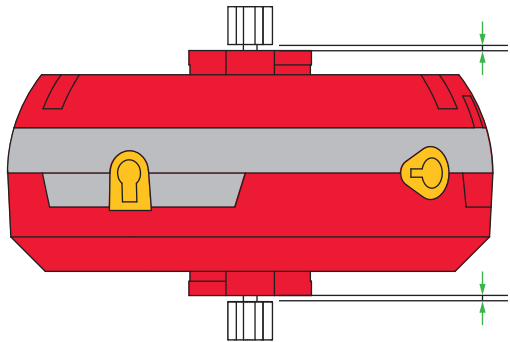
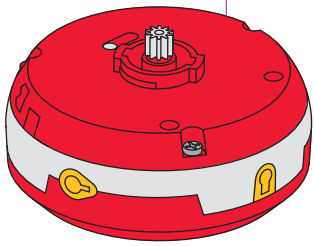

1:1



Spatiu liber trebuie sa fie identic !

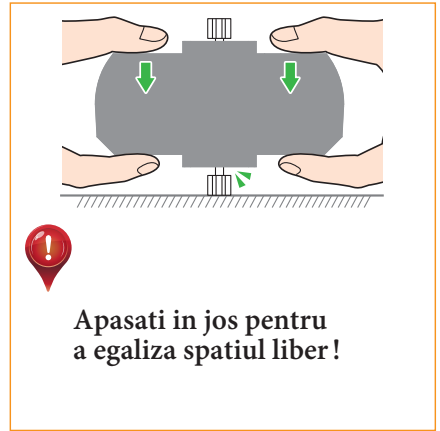
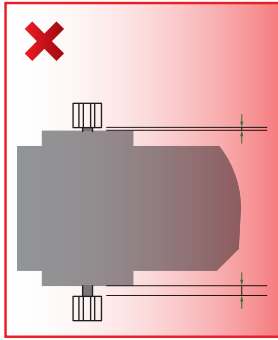
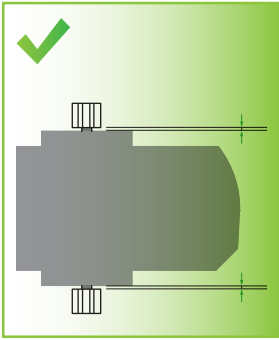

TEST



ATENTIE! Nu trageti niciodata de cremaliera cand giroscopul este pornit!
A nu se lasa la indemana copiilor mici!

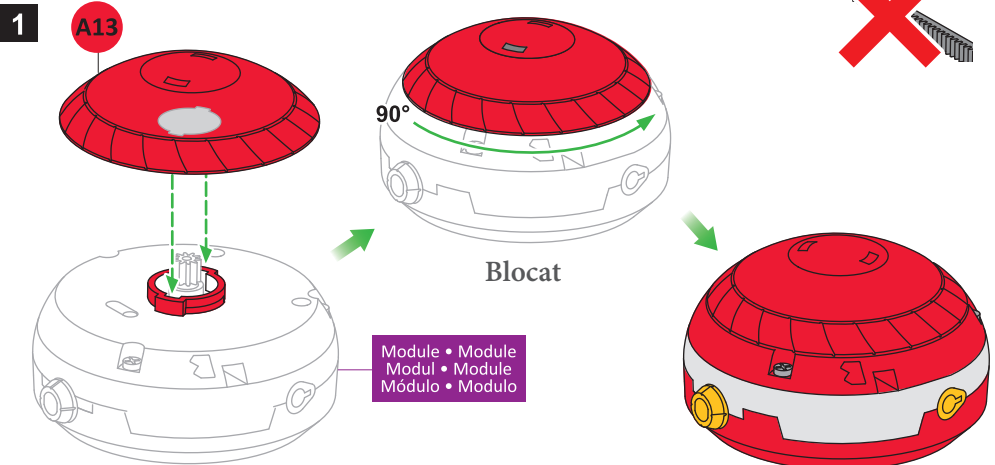
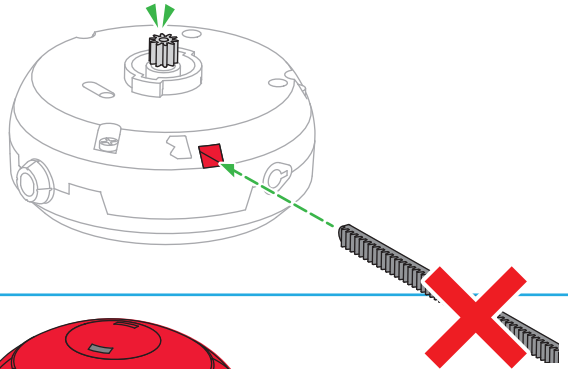
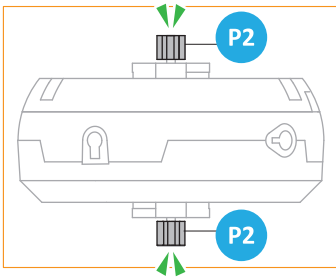

2

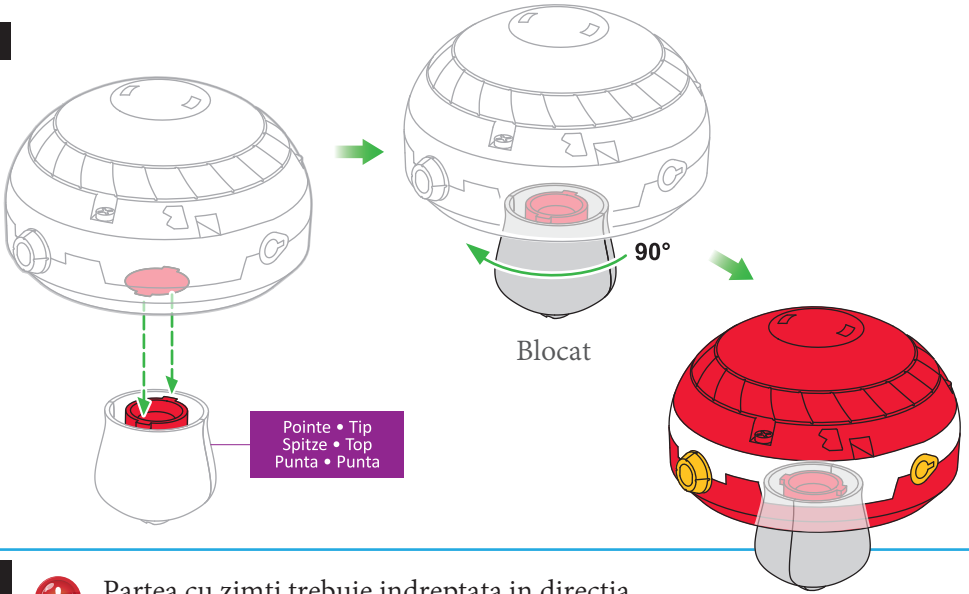

3



Partea cu zimți trebuie îndreptată în direcția semnului.

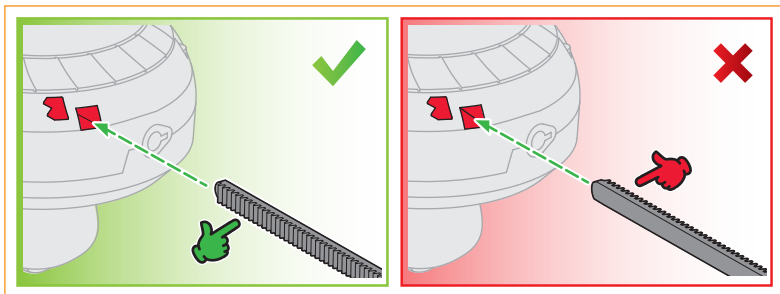
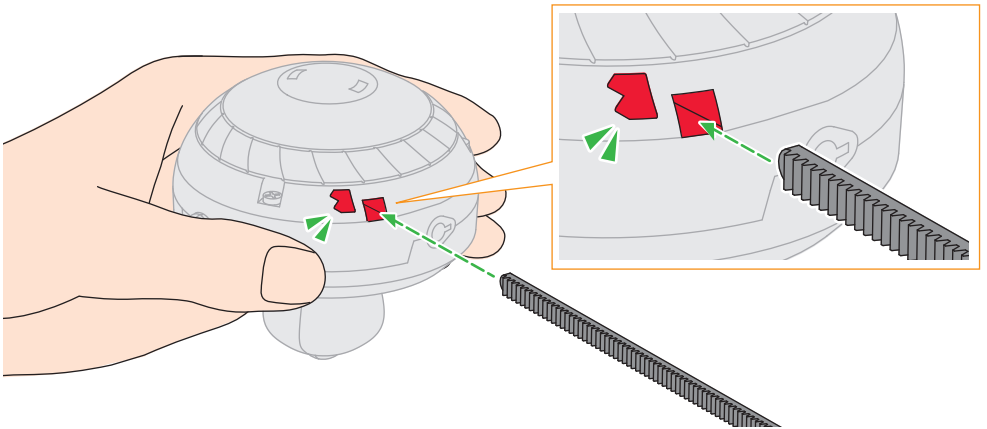



Atentie la contactul cu pielea dvs atunci cand trageți.

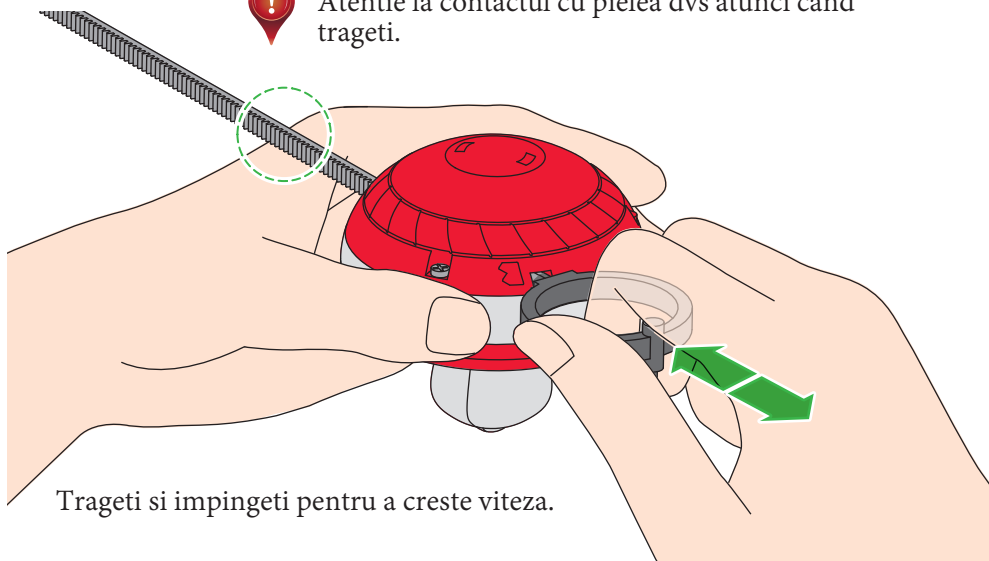

Trageți și împingeți pentru a crește viteza.

Introduceți cremaliera într-una dintre găuri pentru a opri rotorul.

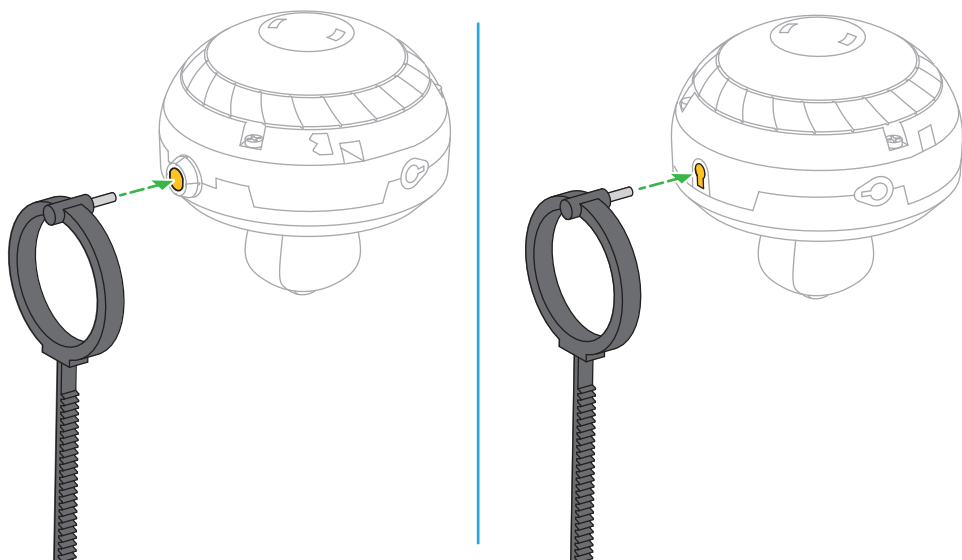

Cutia de viteze

1

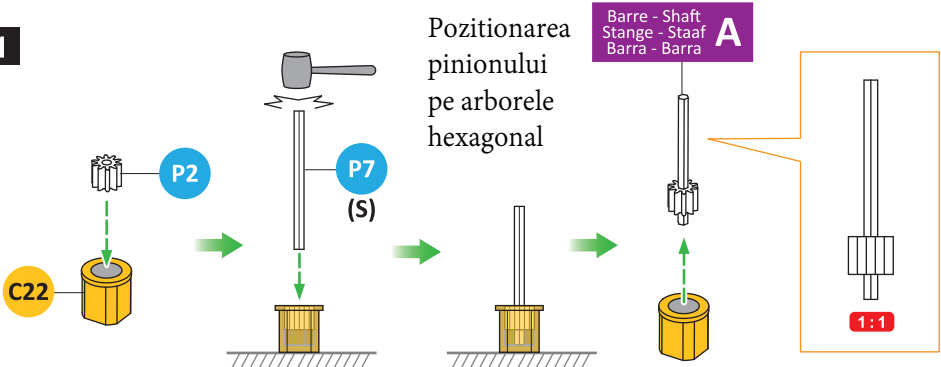

2

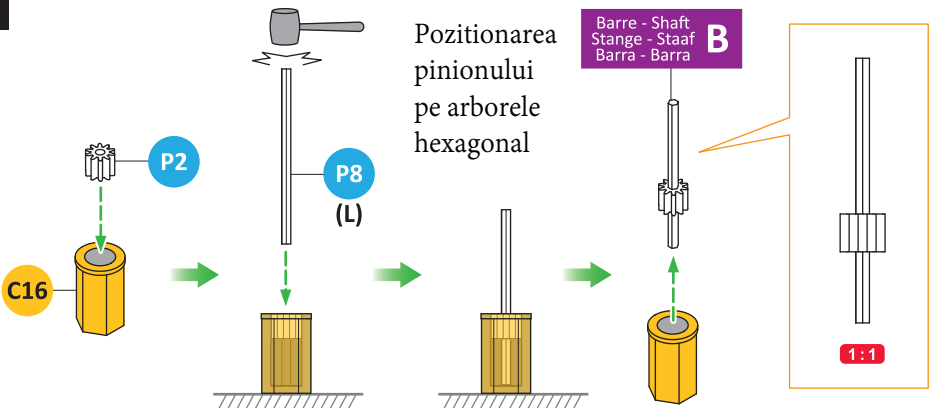

3

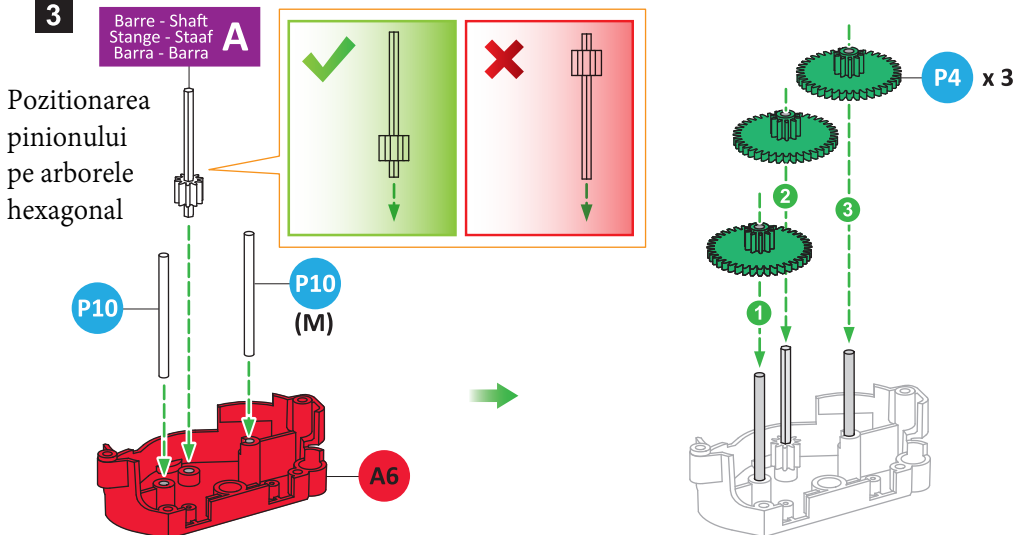

4

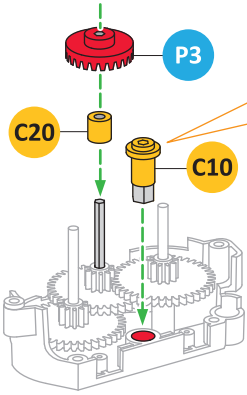

 Taiati cu atentie

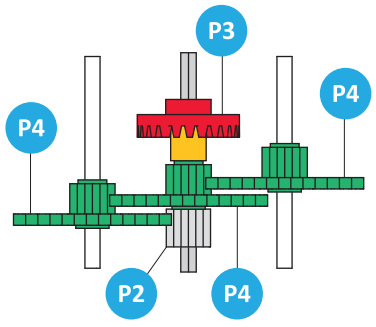
5

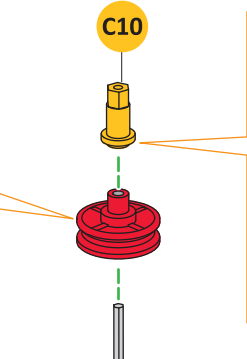
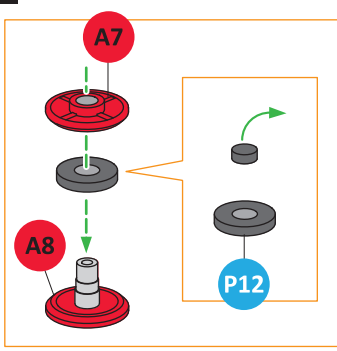

 Taiati cu atentie

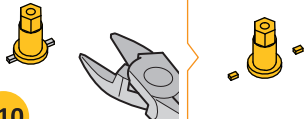

Barre - Shaft
Stange - Staaf
Barra - Barra

B

Pozitionarea
pinionului pe
arborele hexagonal

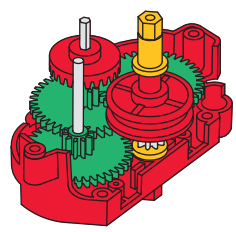
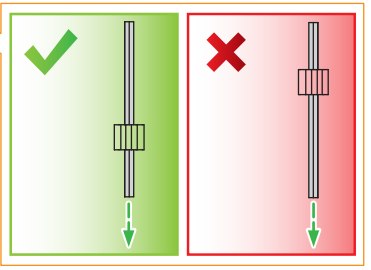
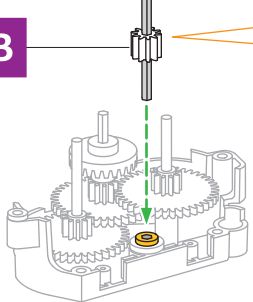

6

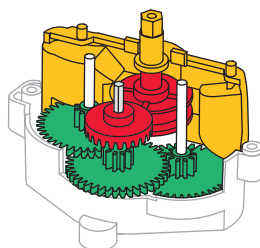
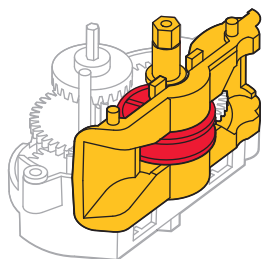
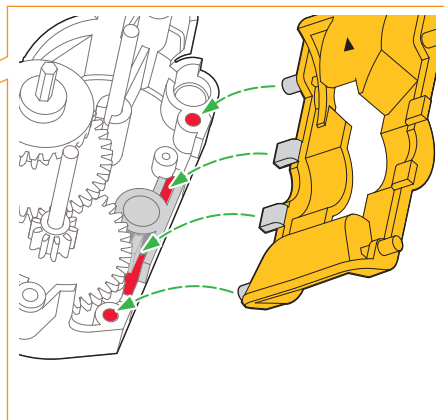
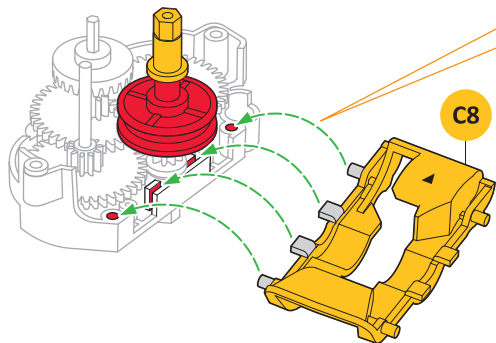

7

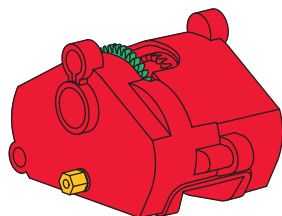
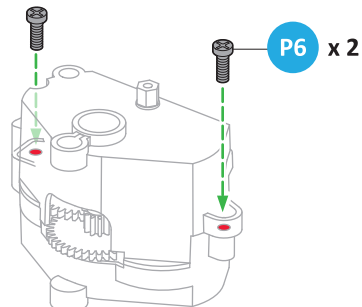
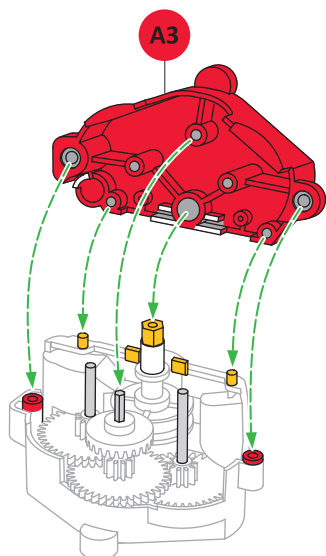

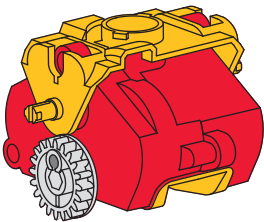
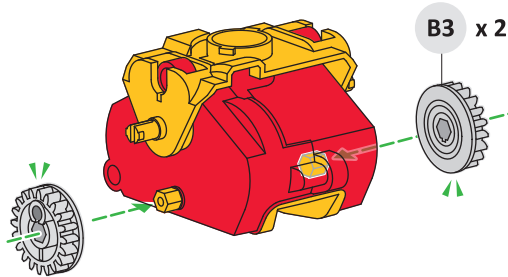
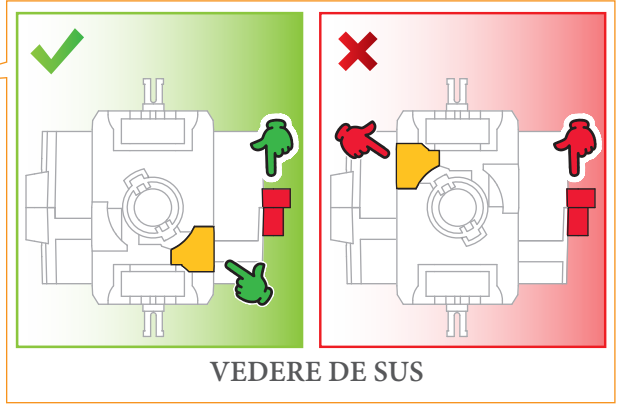
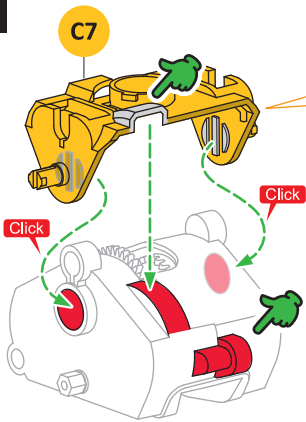

Cutie de viteze

Boîte de vitesse • Gearbox
Getriebe • Versnellingsbak
Caja de engranajes • Scatola di marcia

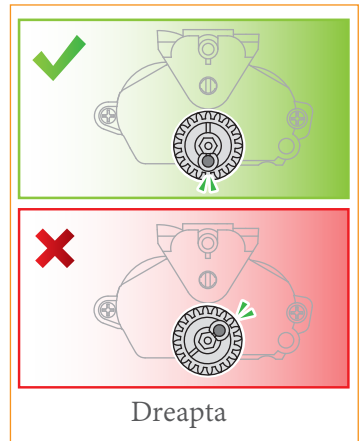
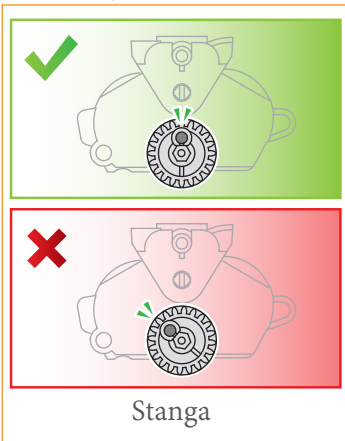
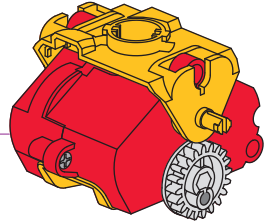

Cum construiești pista?

1

Utilizati o cutie

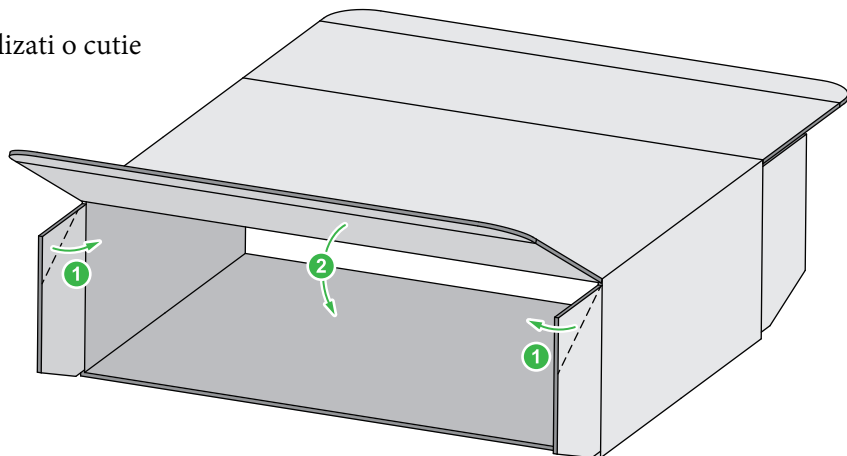

Indoiti colturile spre interior.

Utilizati banda adeziva

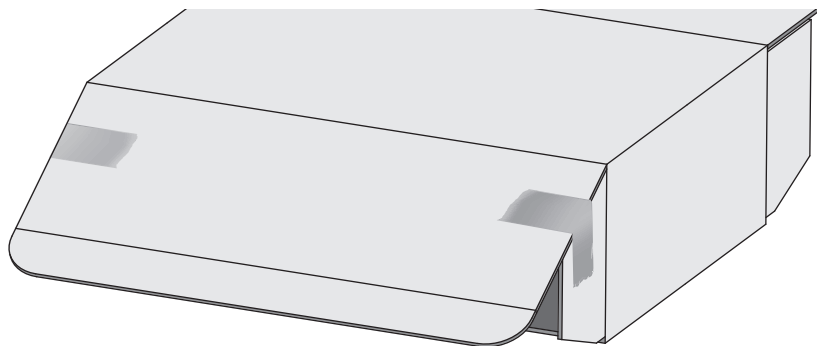
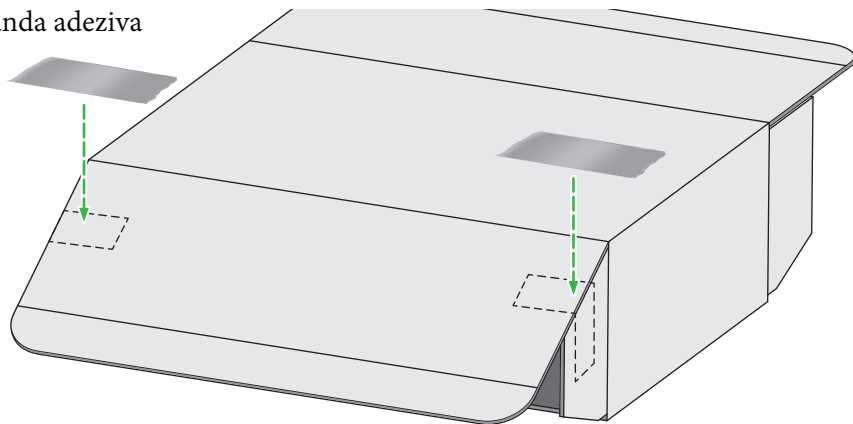

2

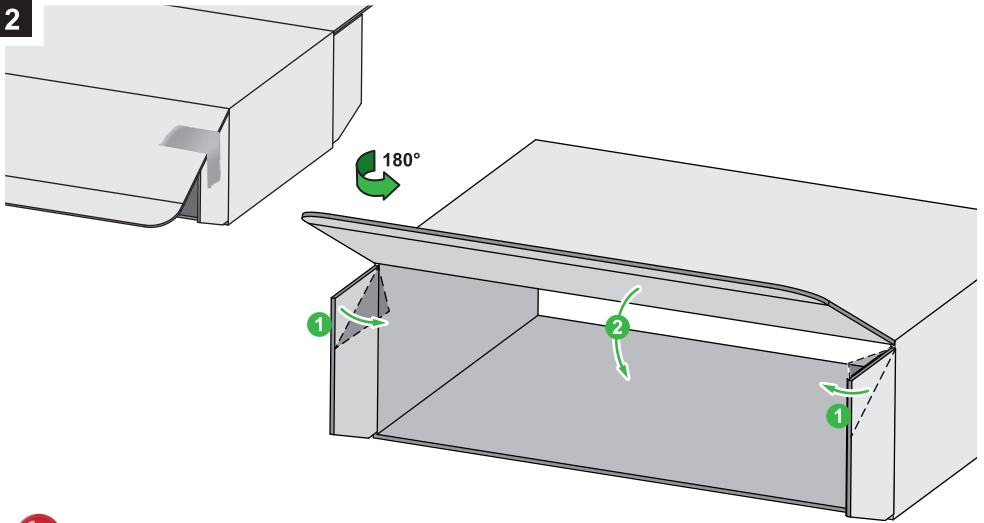

Indoiti colturile spre interior.

Utilizati banda adeziva

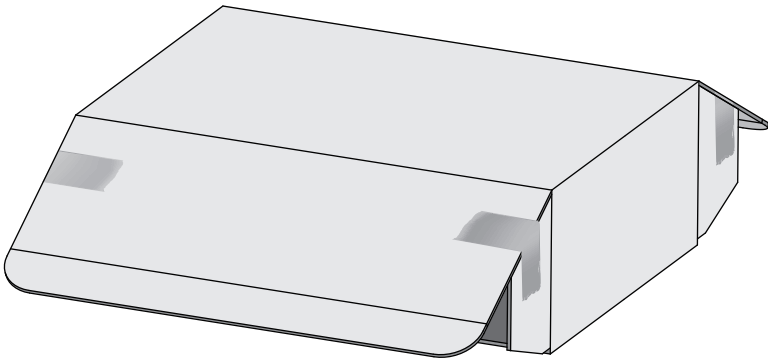
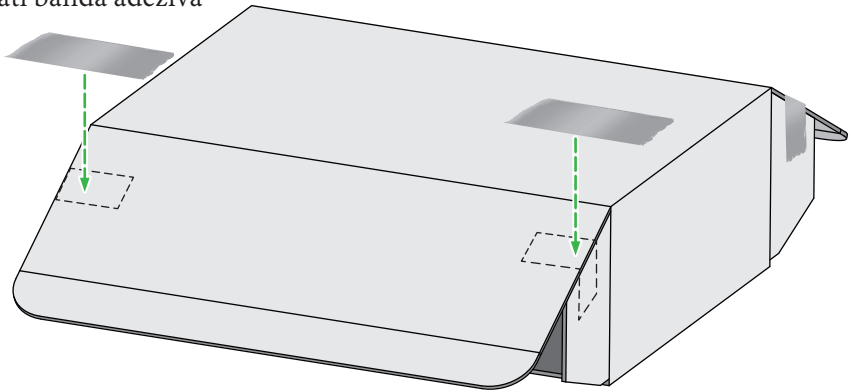

3

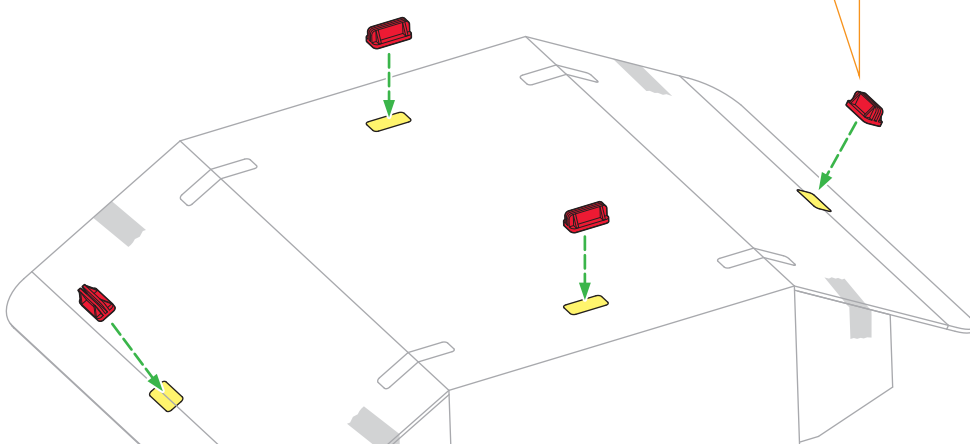
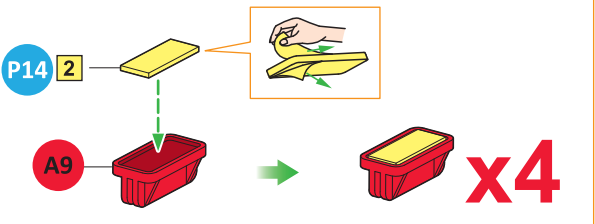
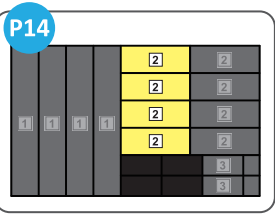

4

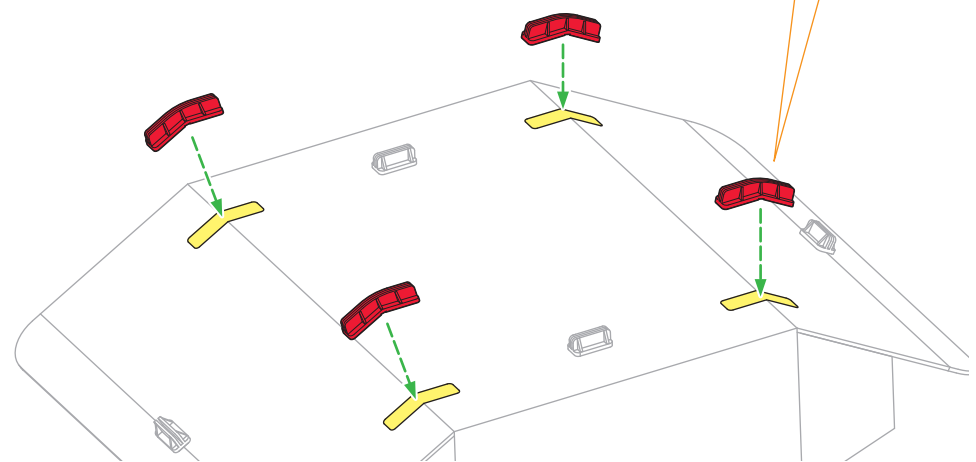
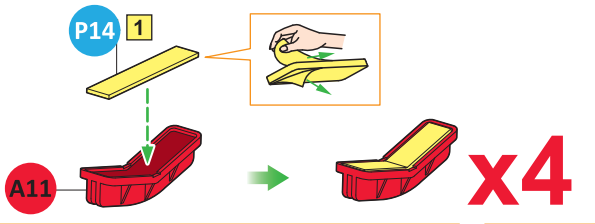
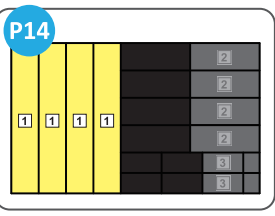

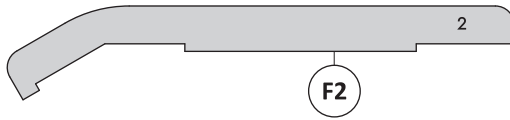

x4

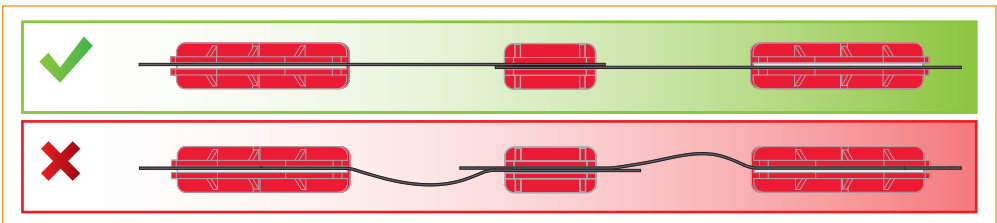
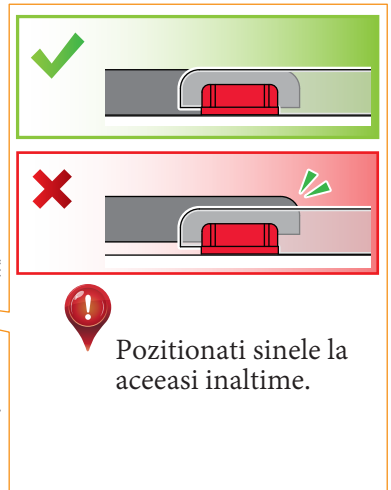
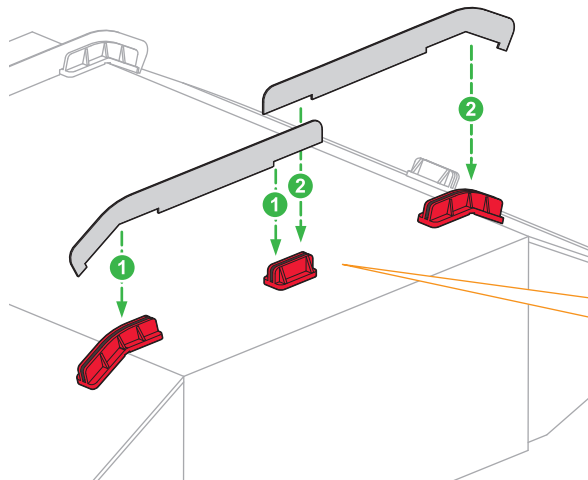
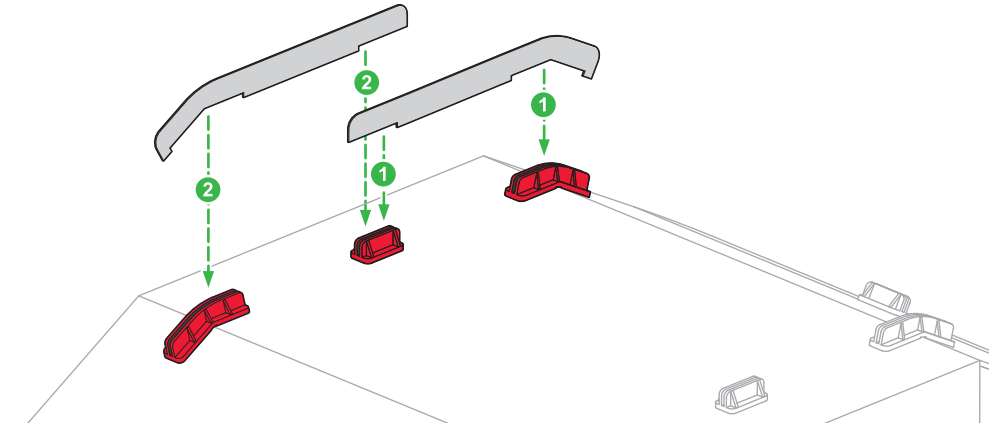

6

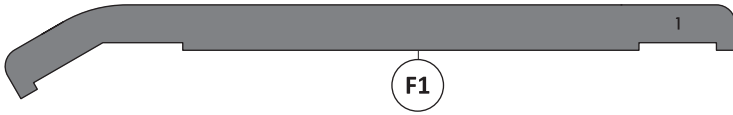

x4



Pozitionati F1 in exteriorul lui F2.

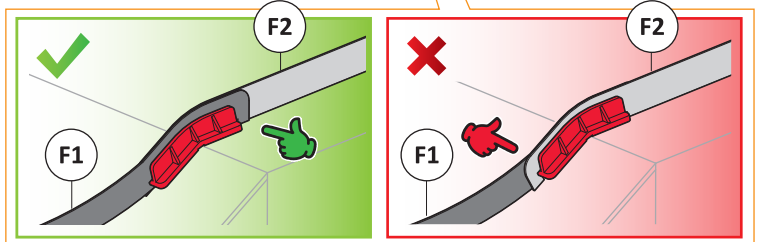
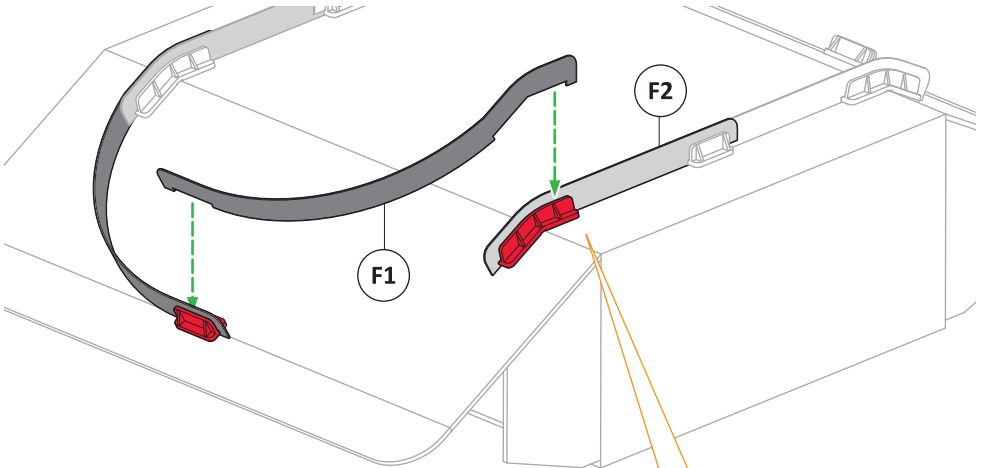
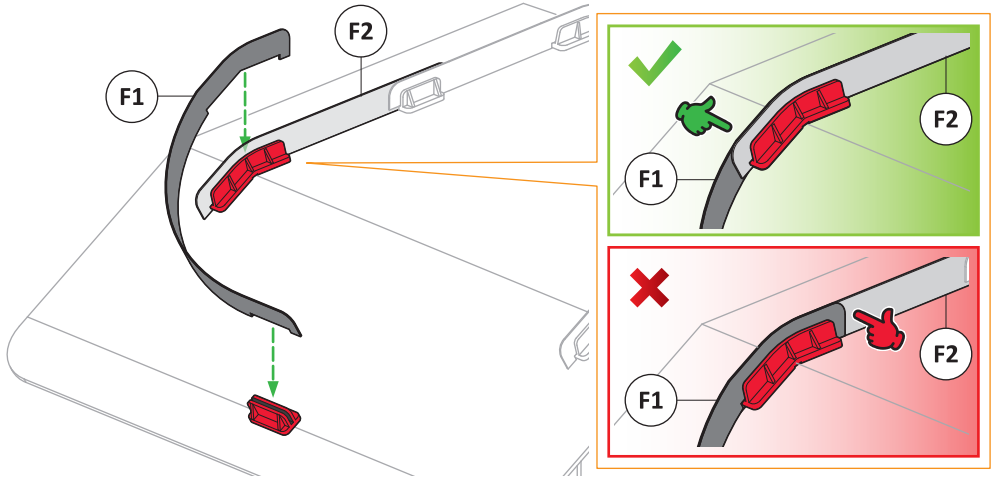

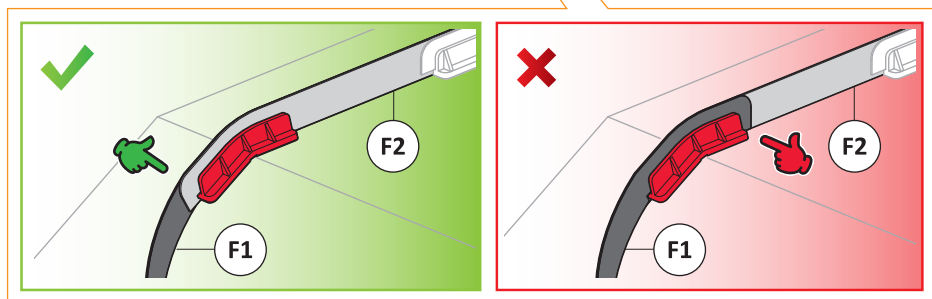
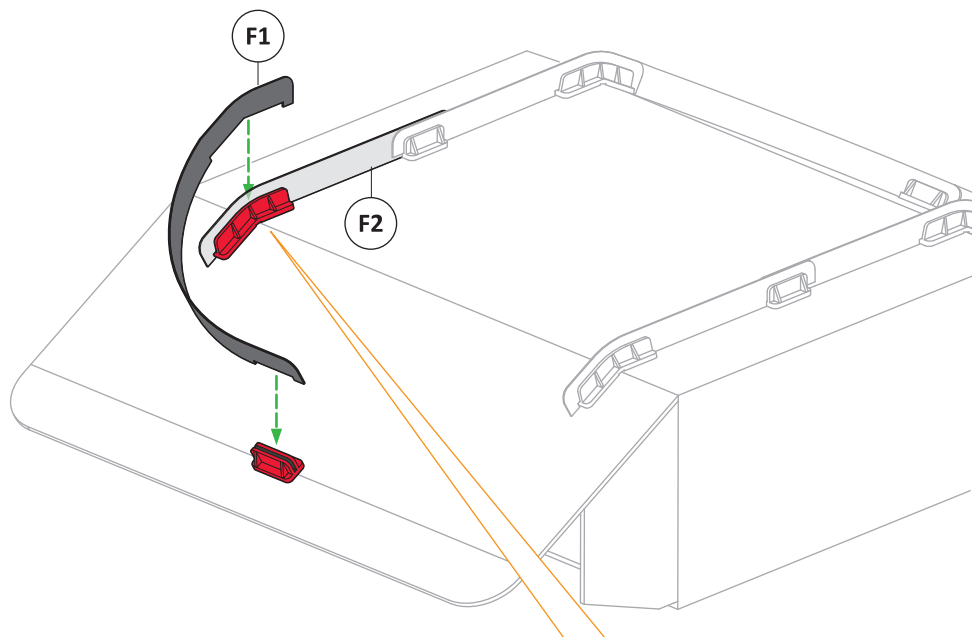
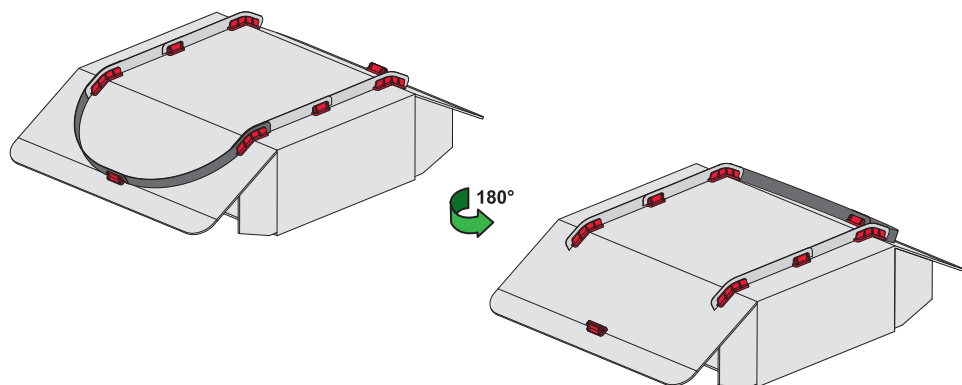

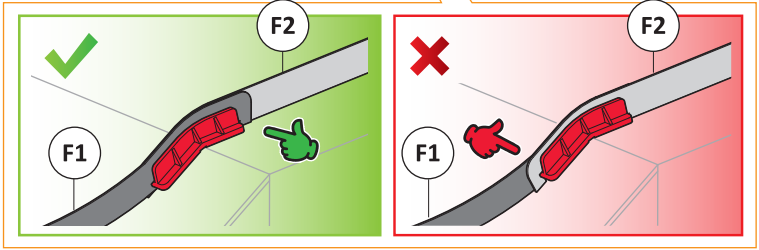
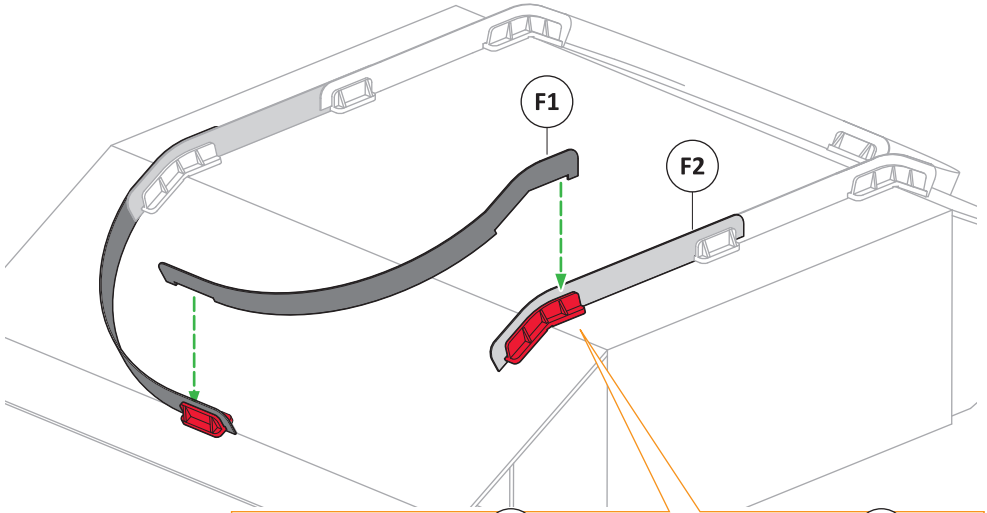

7

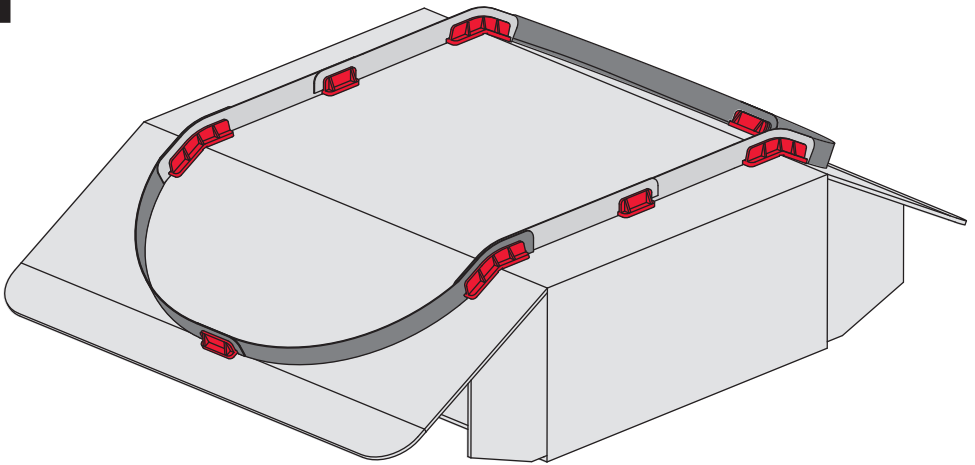

Titirez

1

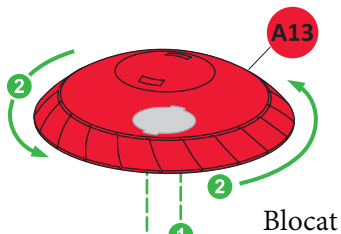

Module • Module
Modul • Module
Módulo • Modulo

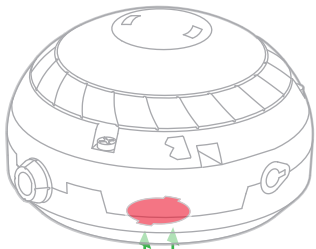
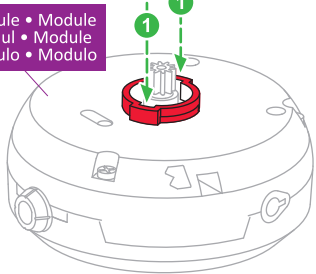

Pointe • Tip
Spitze • Top
Punta • Punta

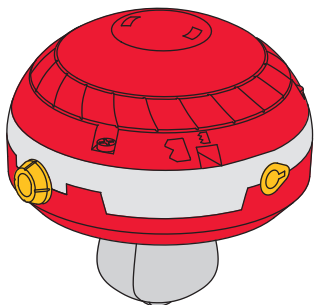
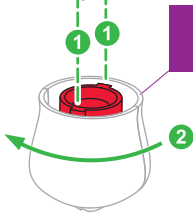

2



Taiati cu atentie!

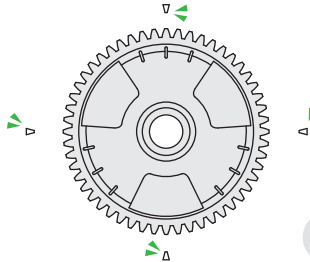

B5

Baza

Base • Base
Basis • Onderstel
Base • Base

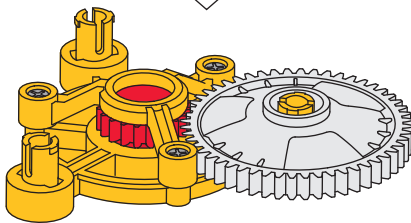
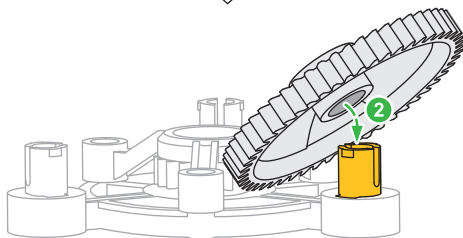
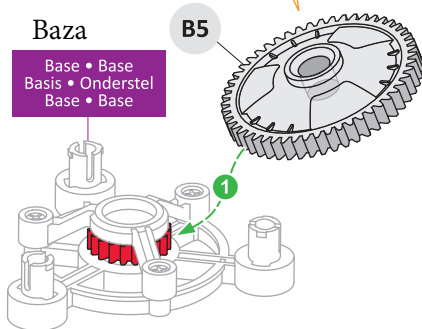

3

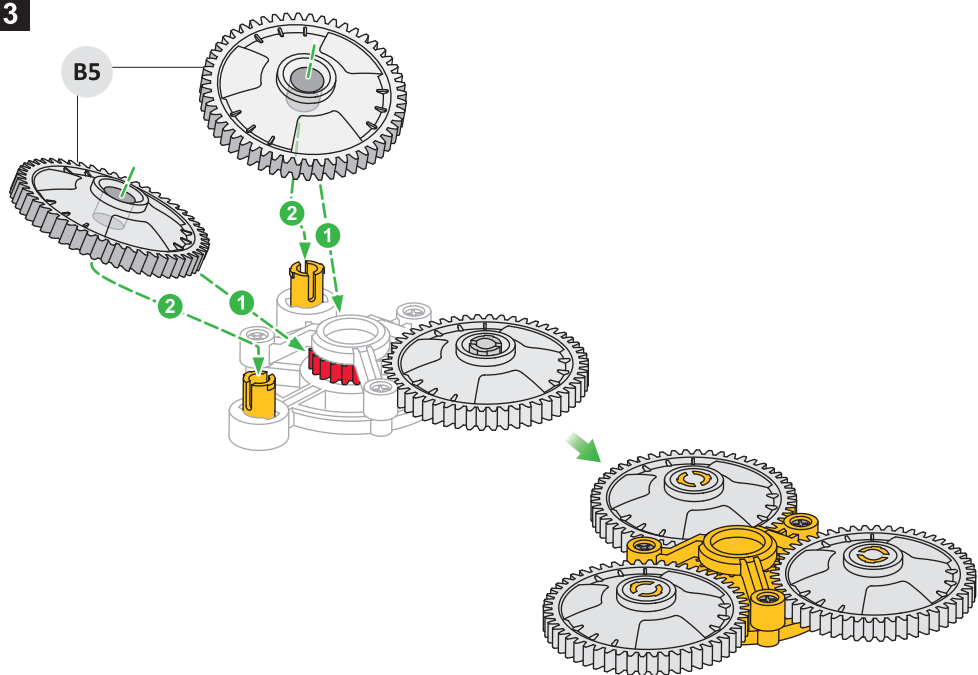

4

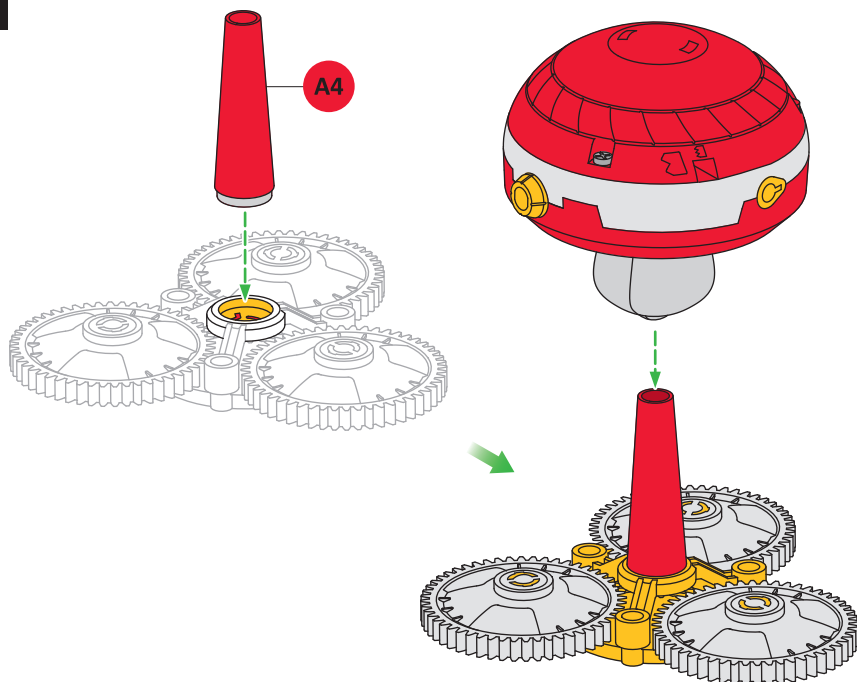

Cum functioneaza?



Trageti si impingeti cremaliera.

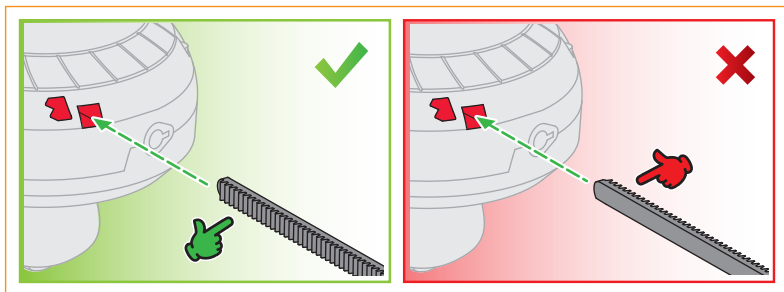
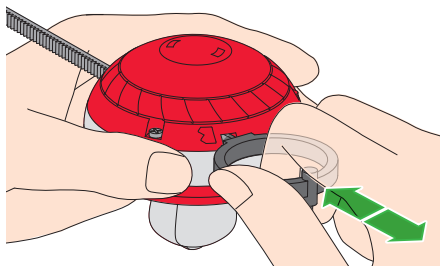
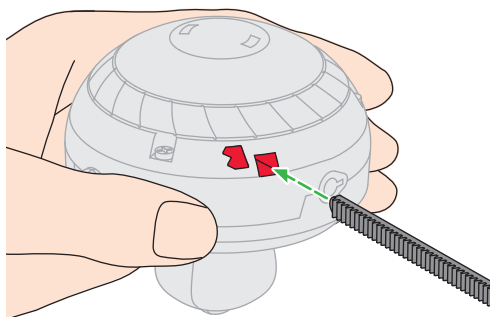

PLAY
1

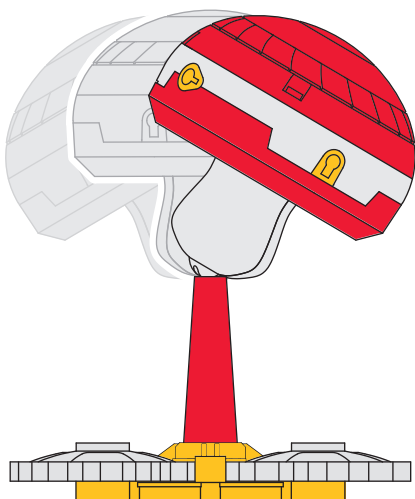

1~5
miscari inainte-
inapoi

PLAY
2

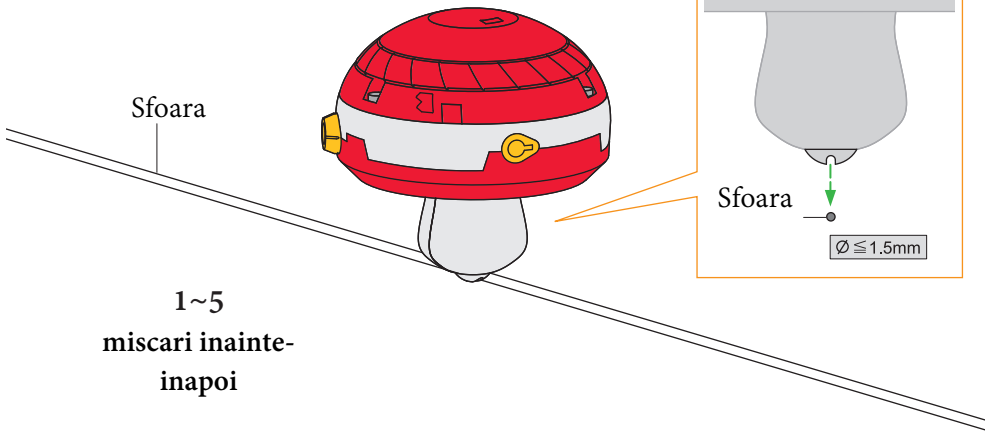

PLAY
3

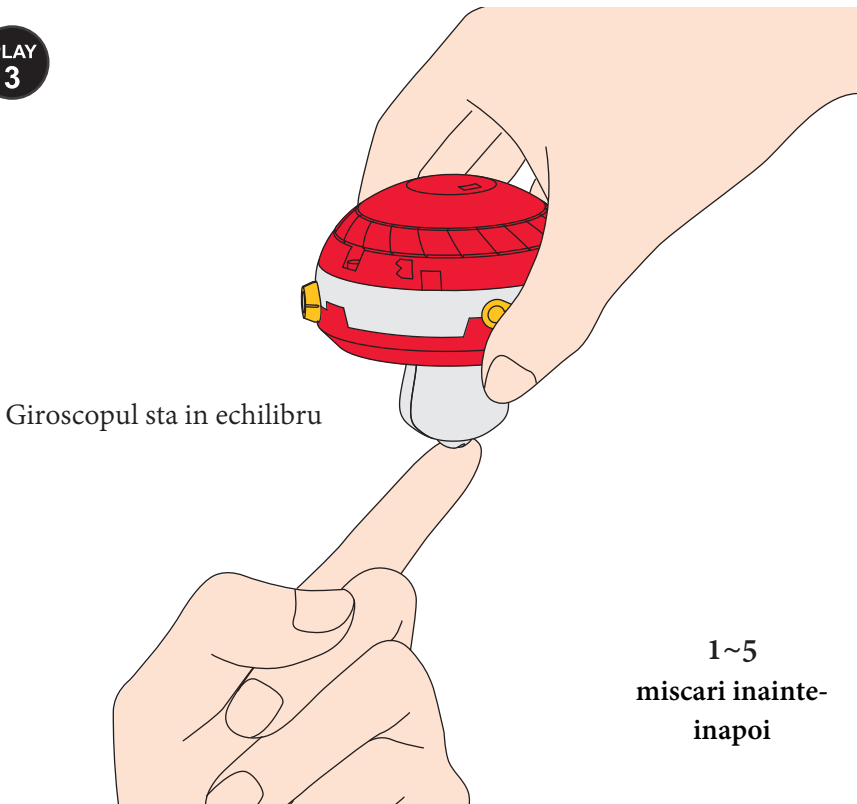

2

Nastrusnicul Robbie



1

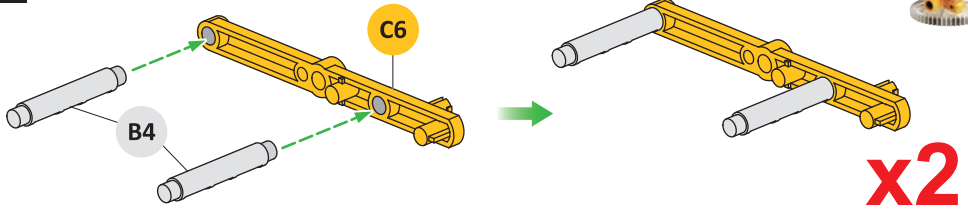

2

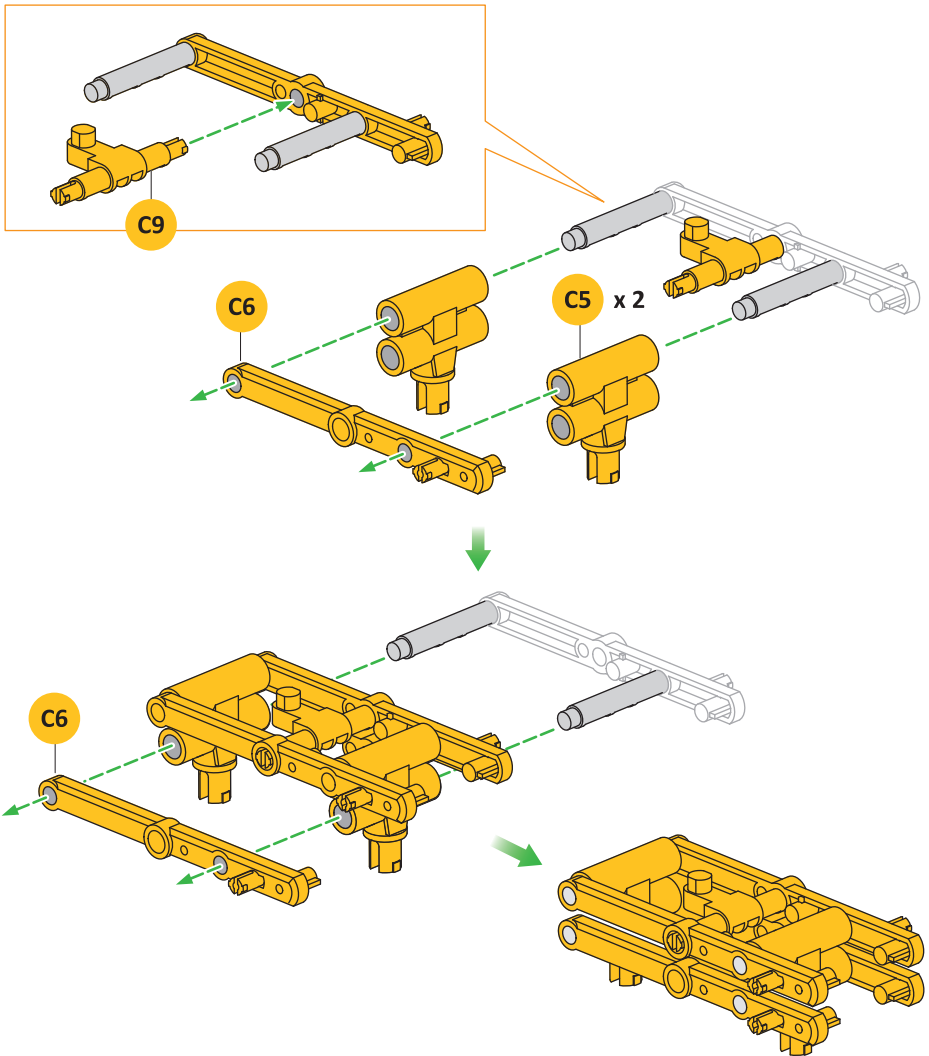

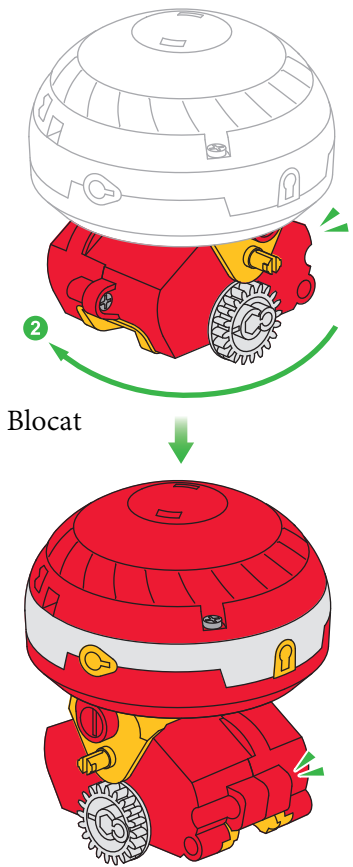
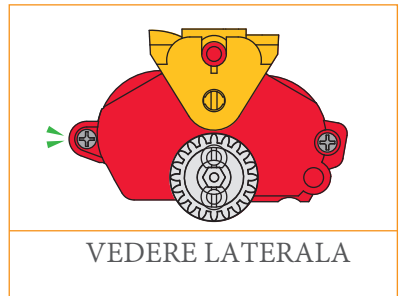
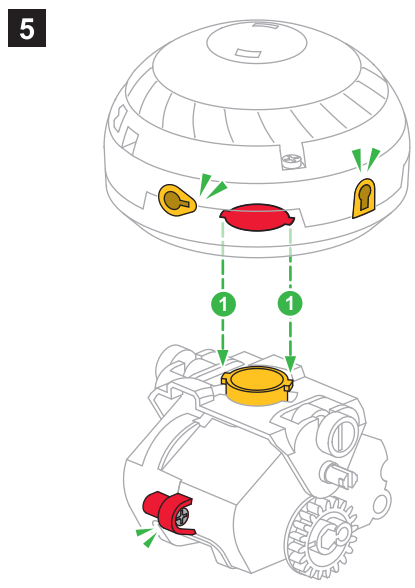
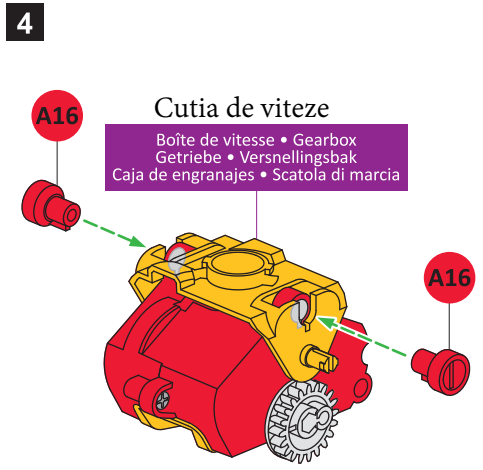
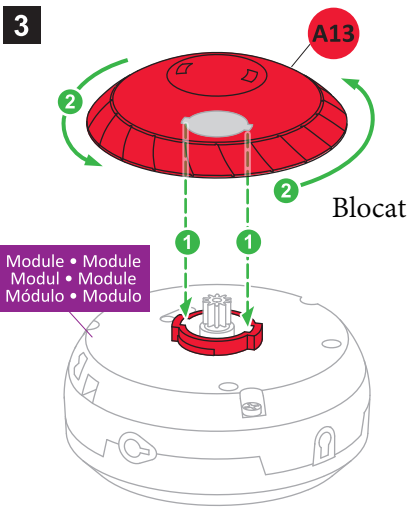

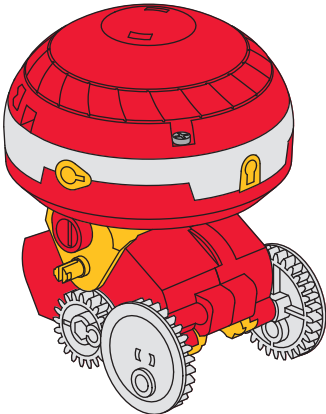
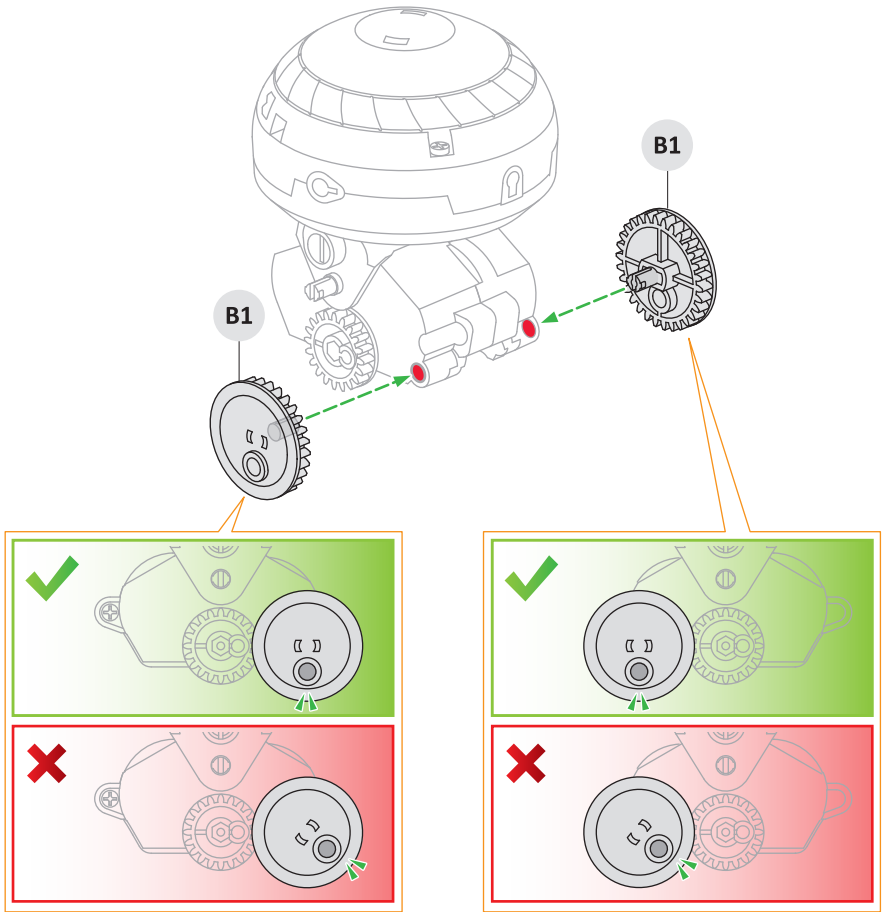

90°

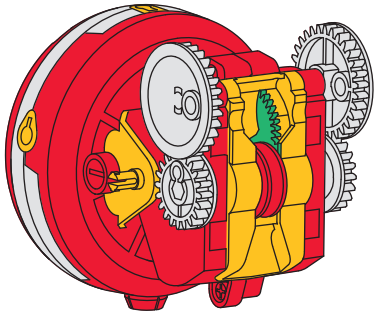

7

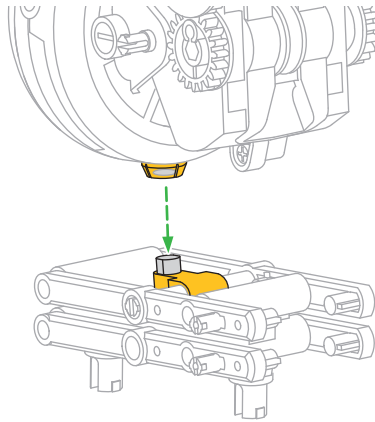

8

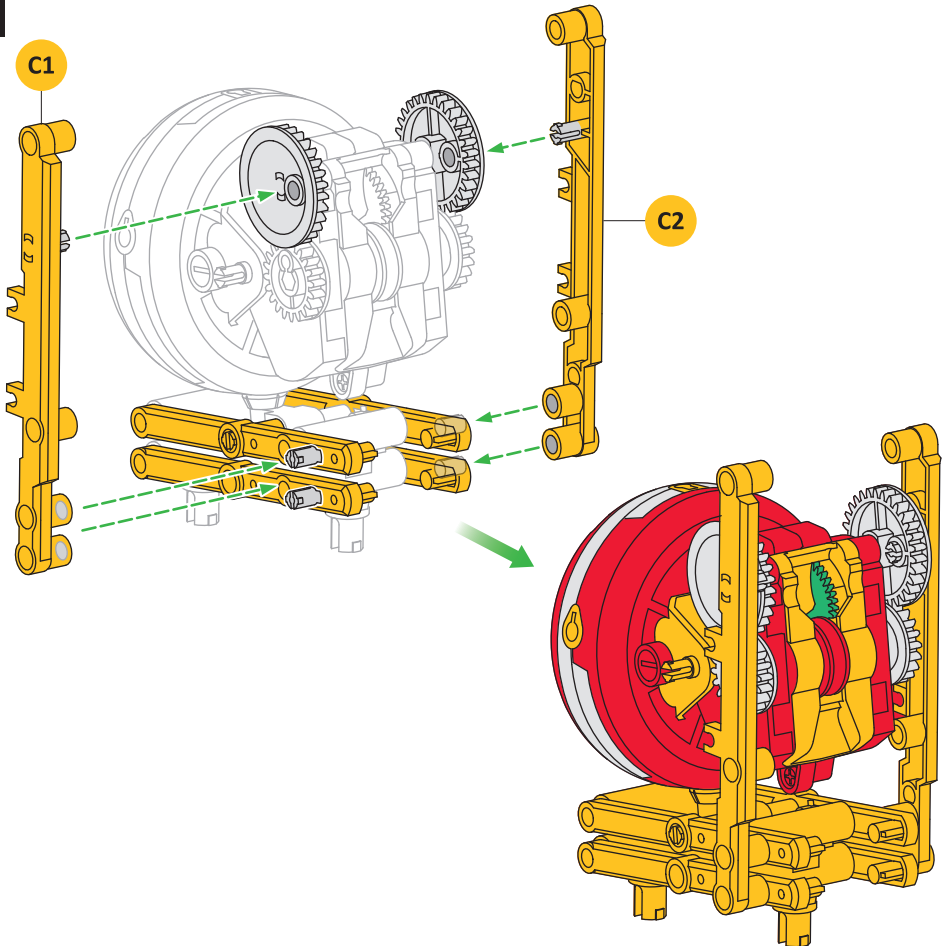

9

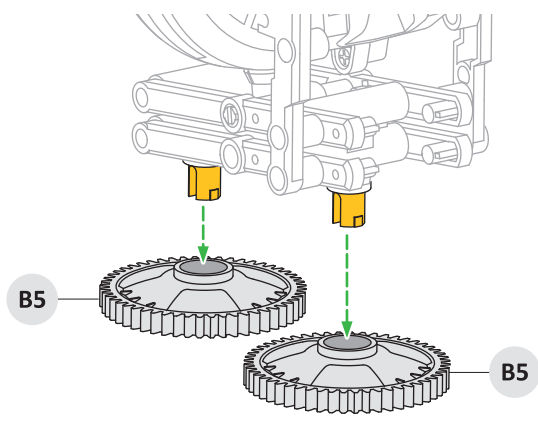

10

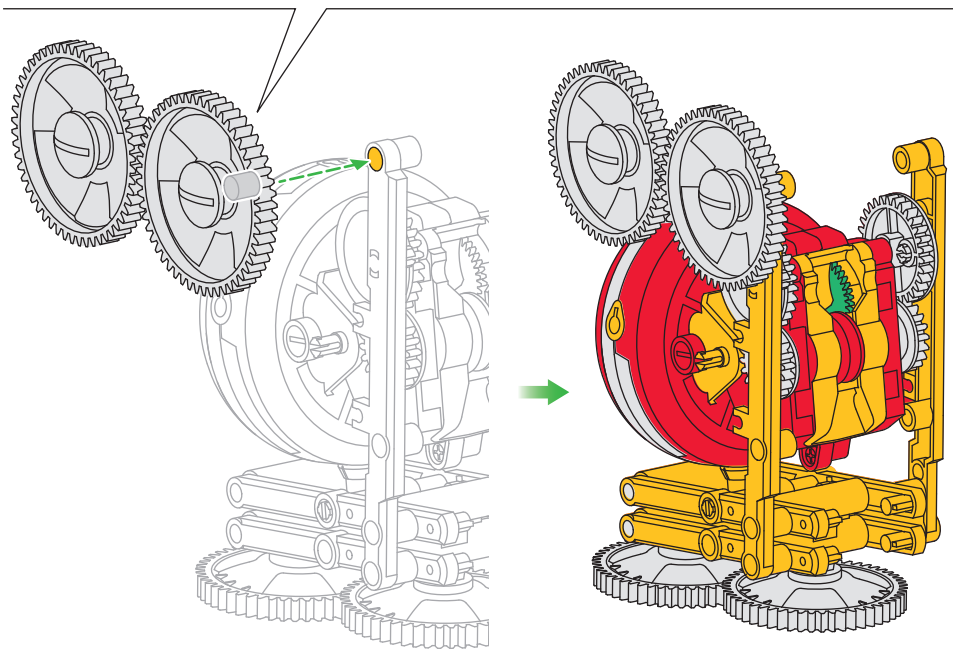
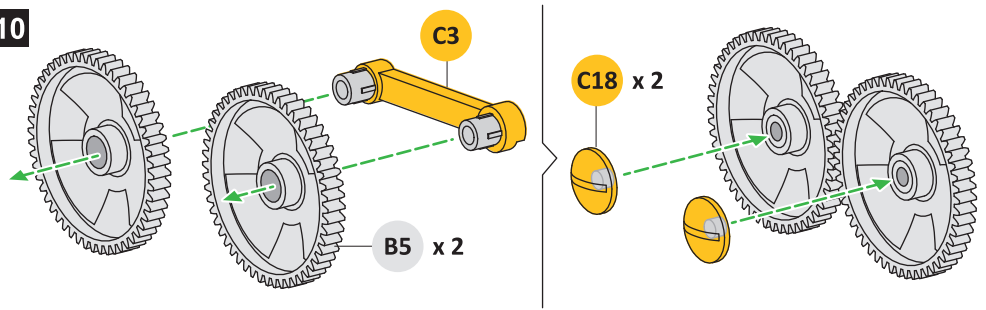

Cum functioneaza?

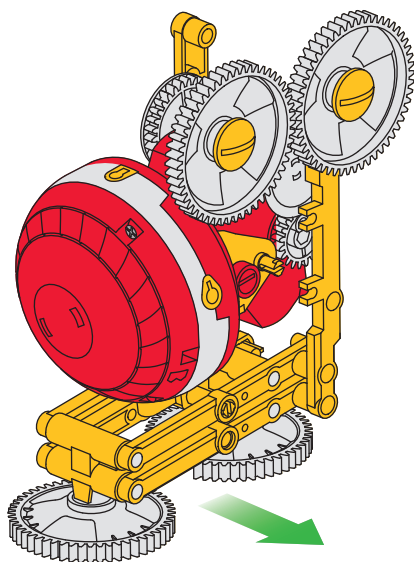
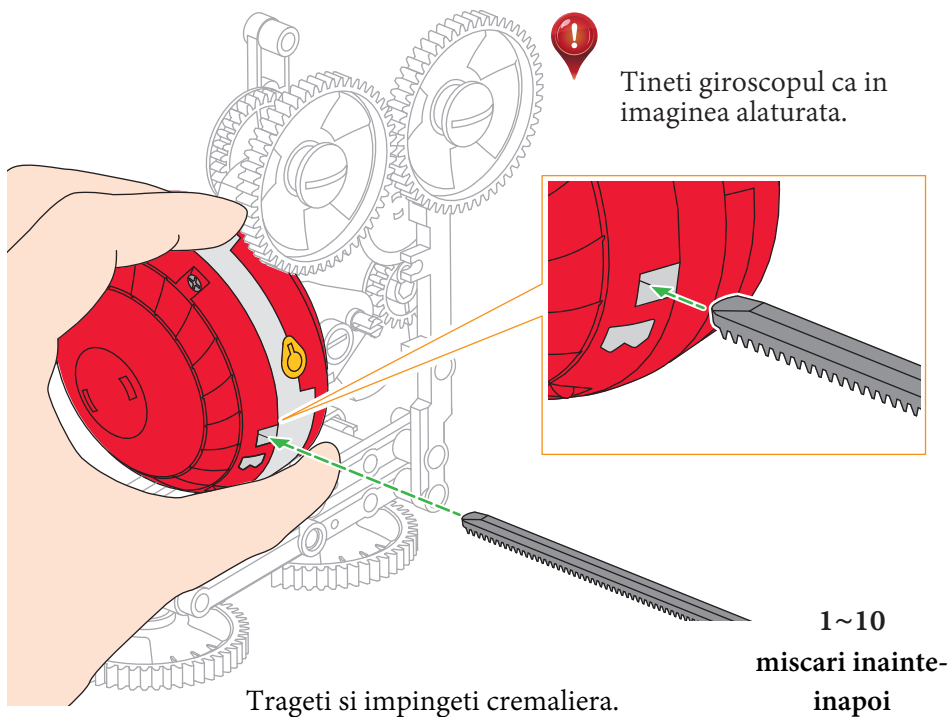

3

Motocicleta

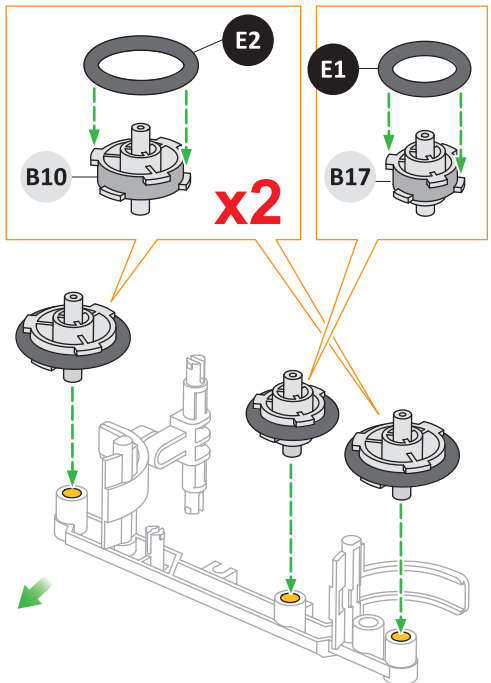
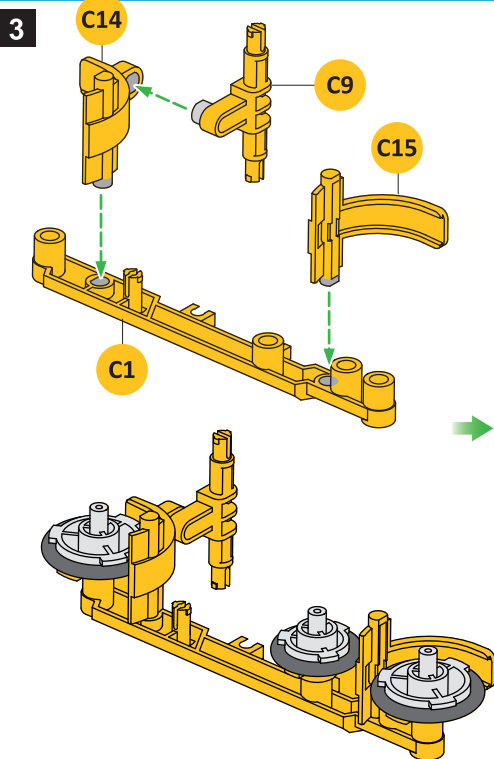
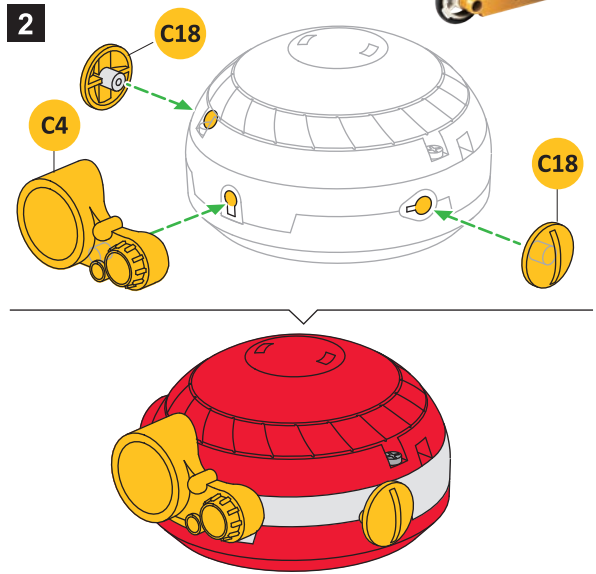
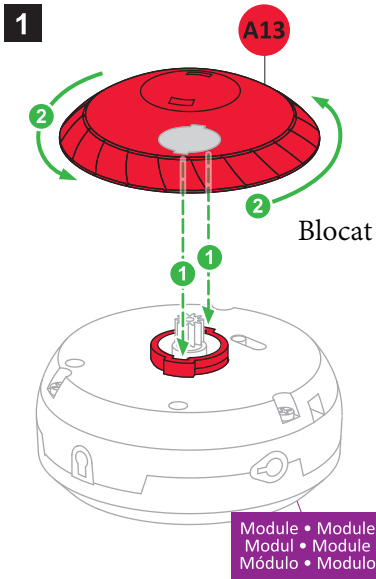

4

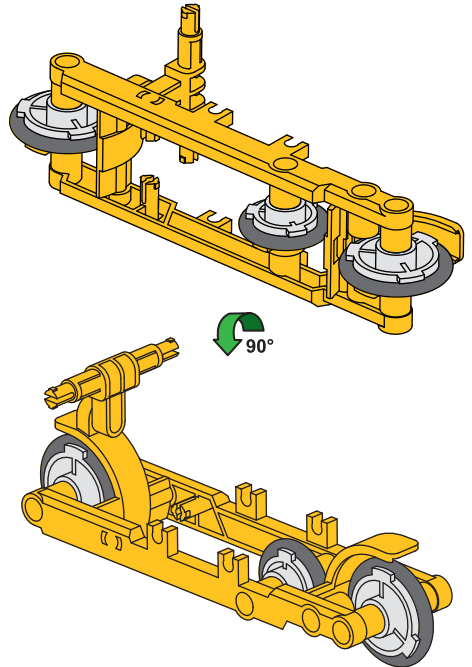
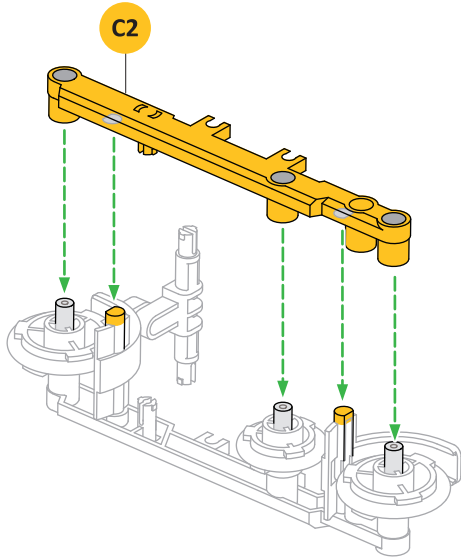

5

Cutia de viteze

Boîte de vitesse • Gearbox
Getriebe • Versnellingsbak
Caja de engranajes • Scatola di marcia

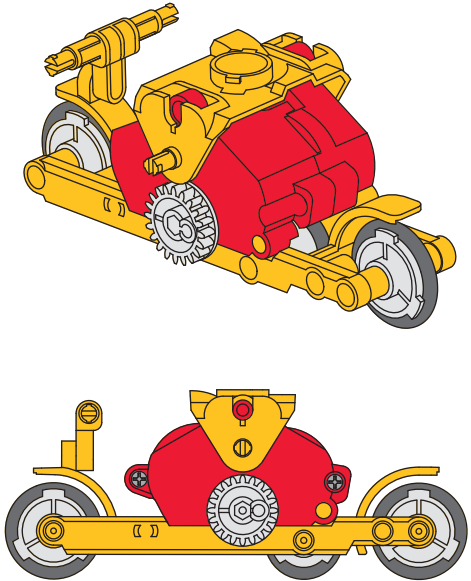
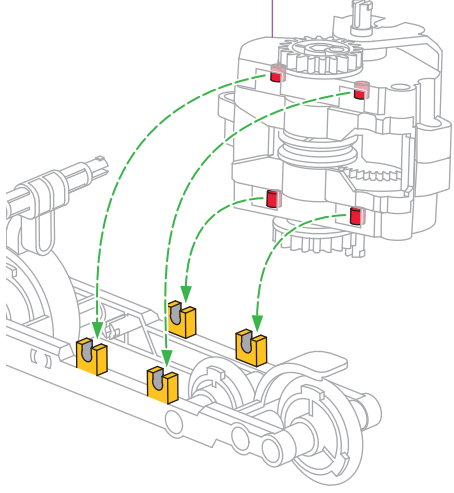

6

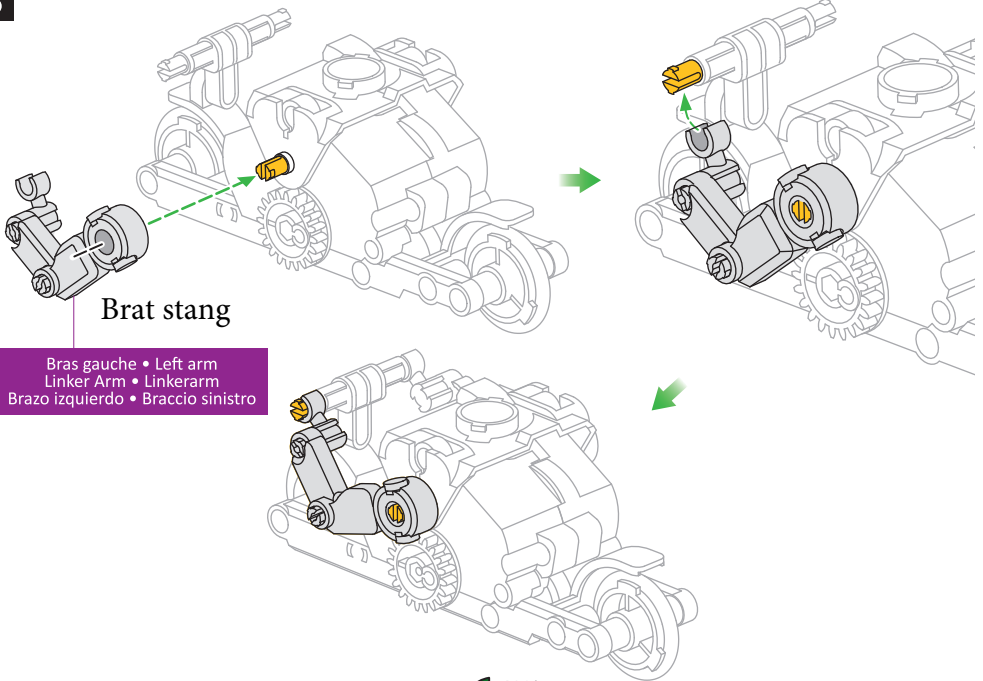

Brat stang

Bras gauche • Left arm
Linker Arm • Linkerarm
Brazo izquierdo • Braccio sinistro

180°

7

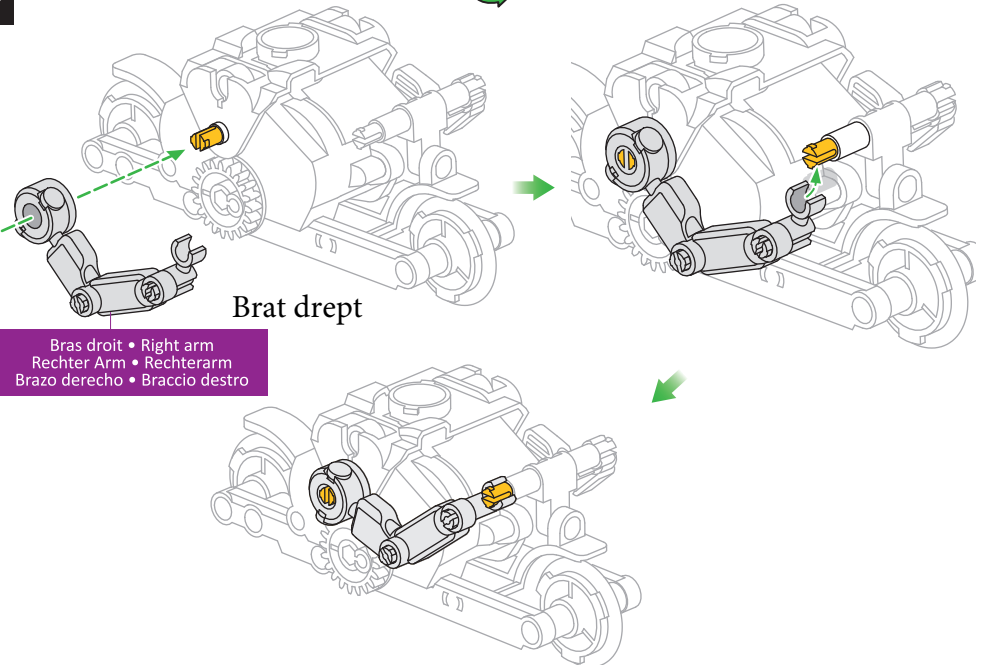

Brat drept

Bras droit • Right arm
Rechter Arm • Rechterarm
Brazo derecho • Braccio destro

8

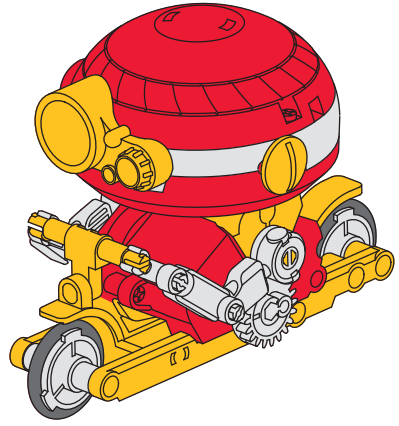
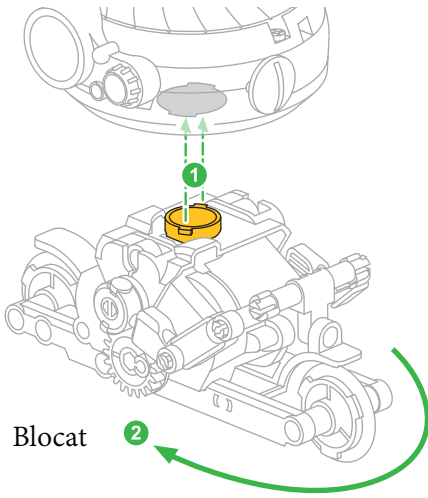

Cum functioneaza?

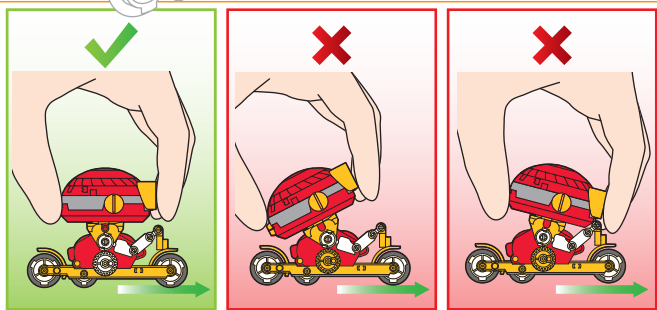
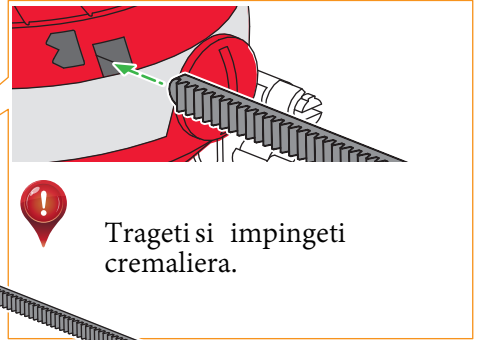
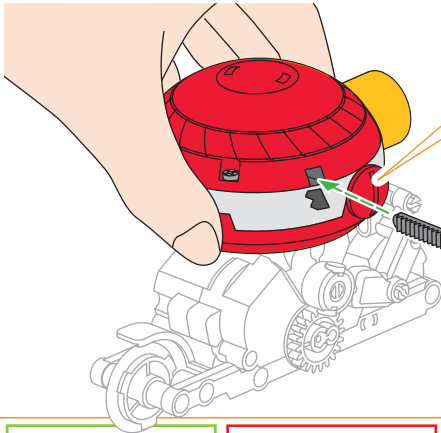

Tineti giroscopul ca in imaginea de mai sus.

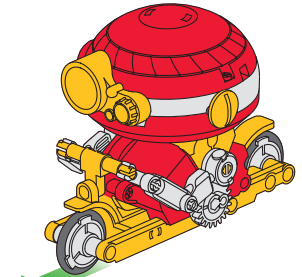

5~10 miscari
inainte-
inapoi

4

Robot pilot



1

Module • Module
Modul • Modul
Módulo • Módulo

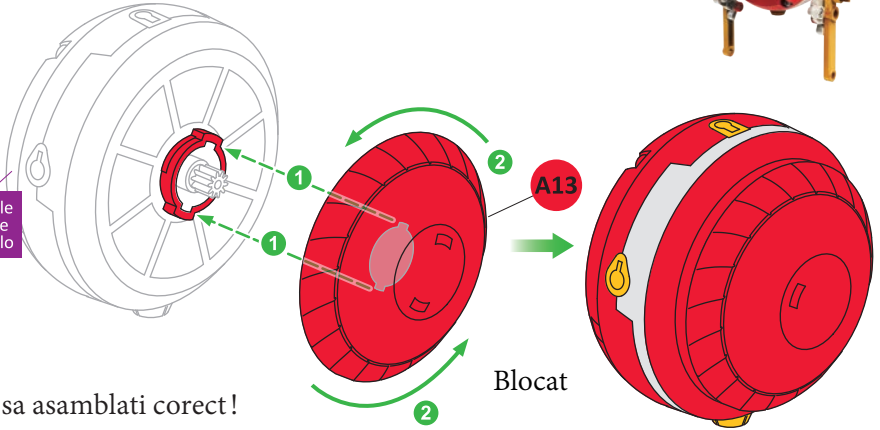

Atentie sa asamblati corect!

2

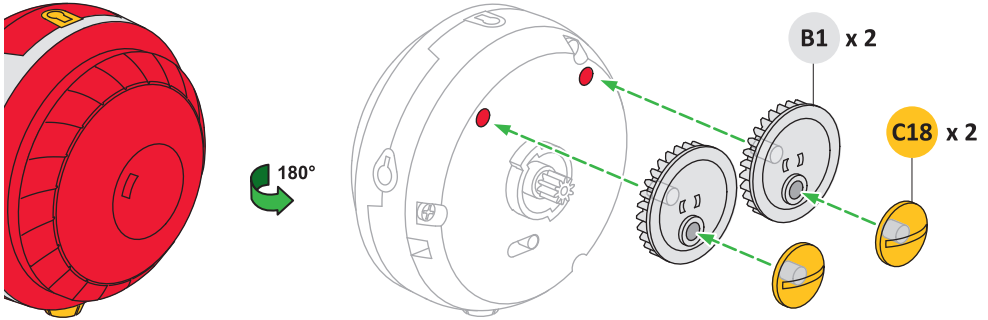

3

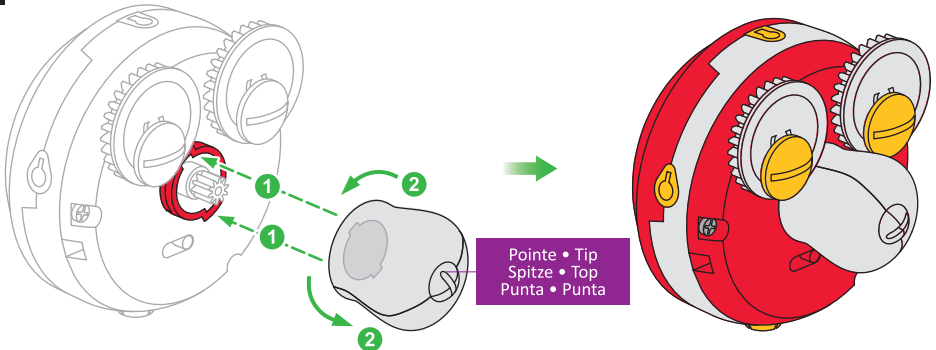

Pointe • Tip
Spitze • Top
Punta • Punta

4

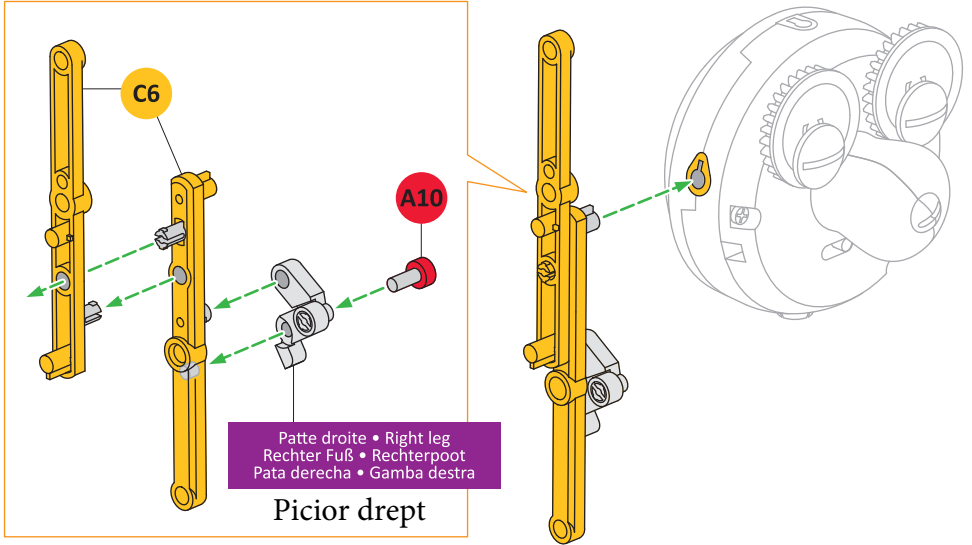

90°

5

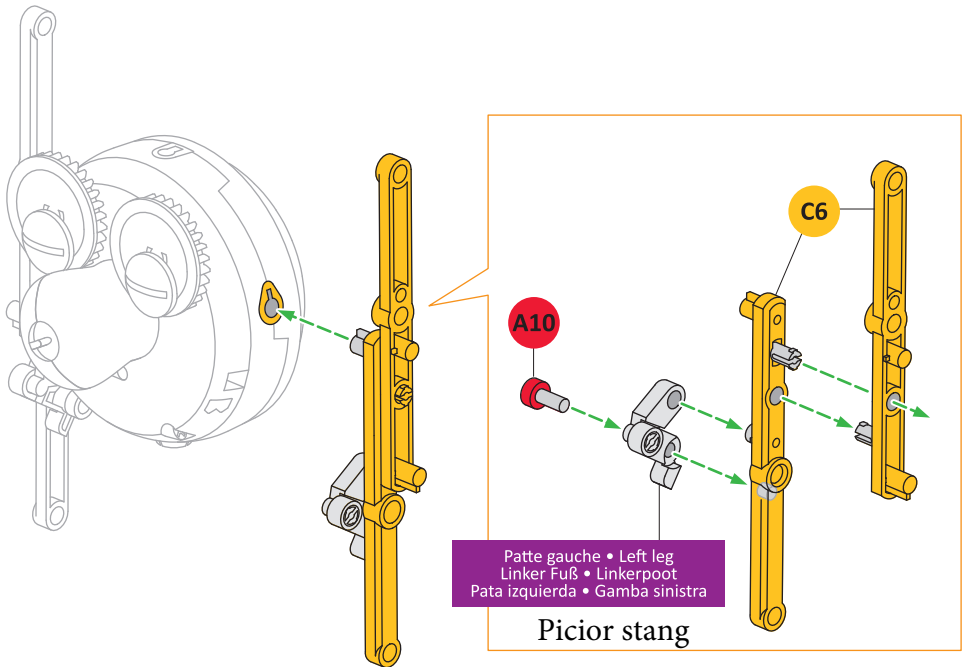

Cum functioneaza?



Tineti giroscopul ca in imaginea de mai jos

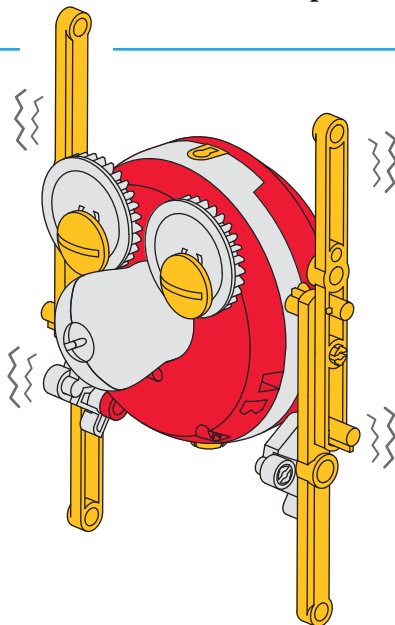
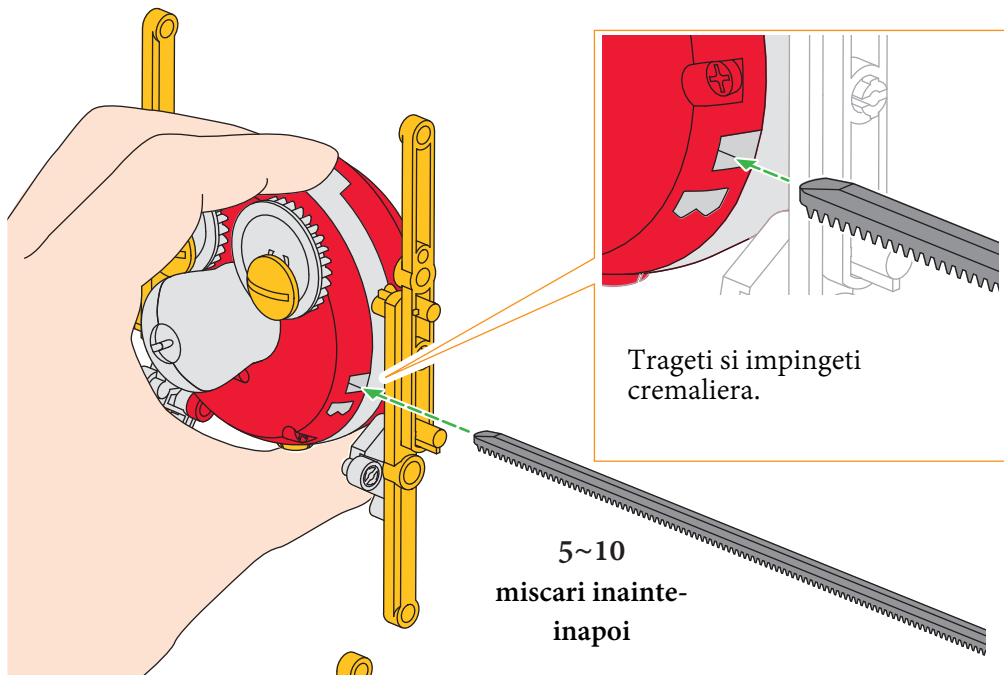

5

Buggy



1

Baza

Base • Base
Basis • Onderstel
Base • Base

B5

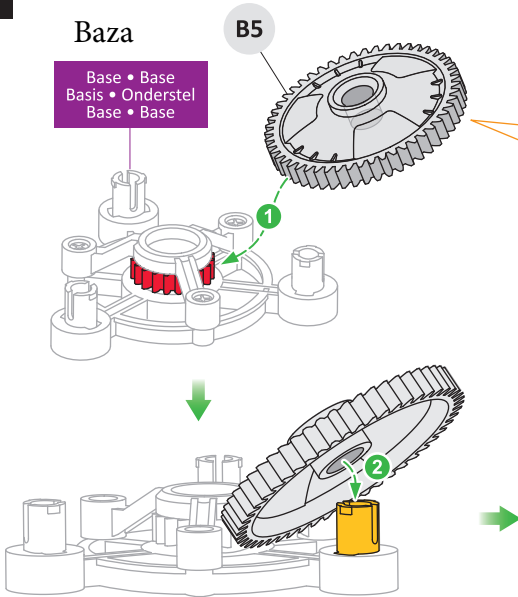

Taiati cu atentie!

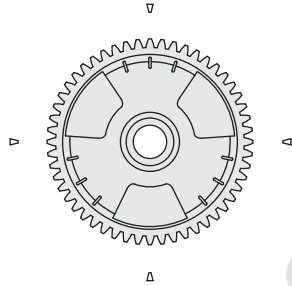

B5

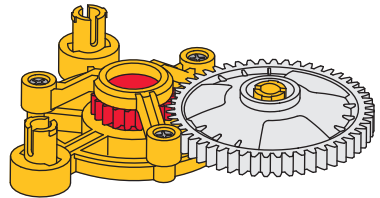

2

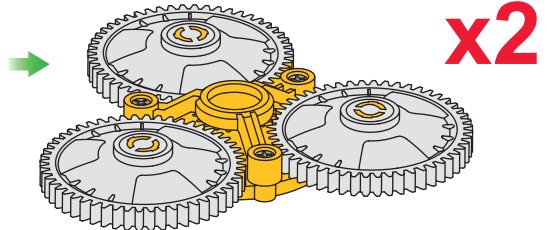
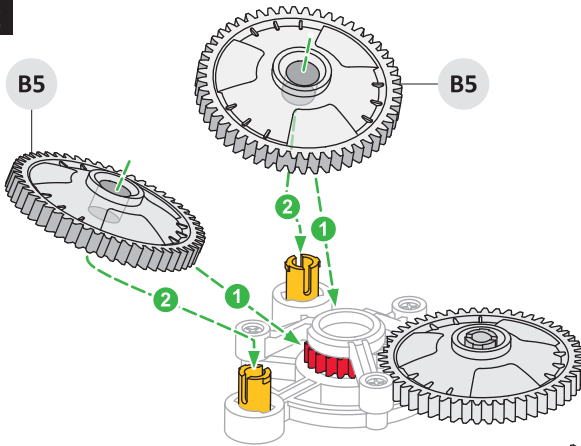

3

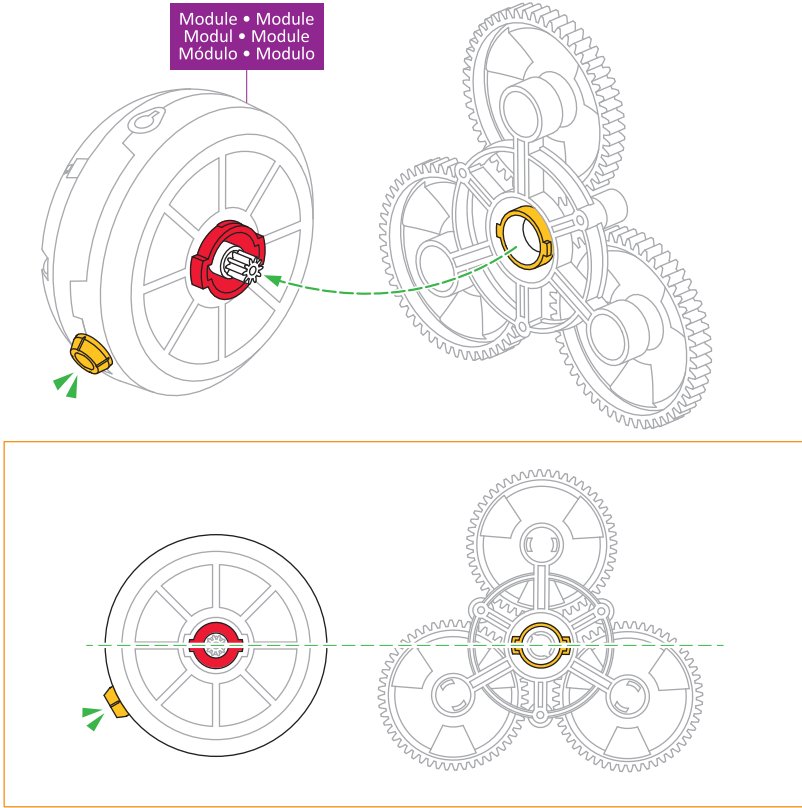

4

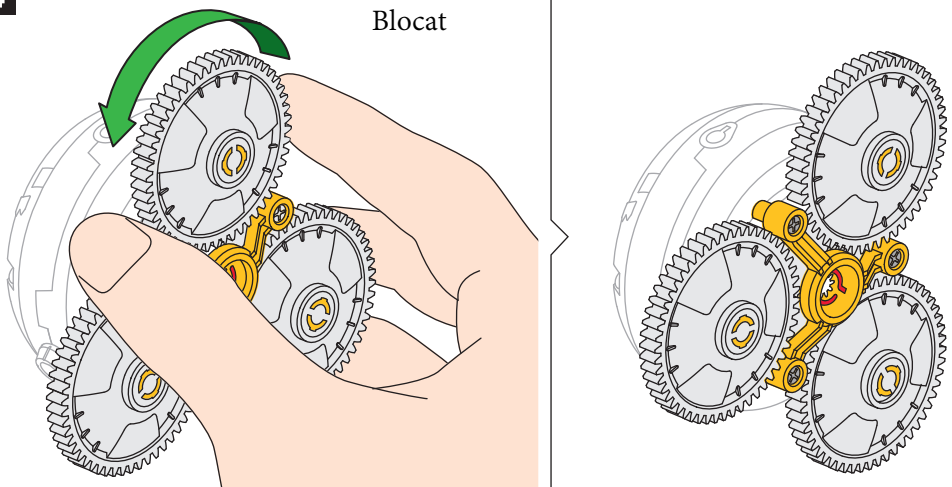

5

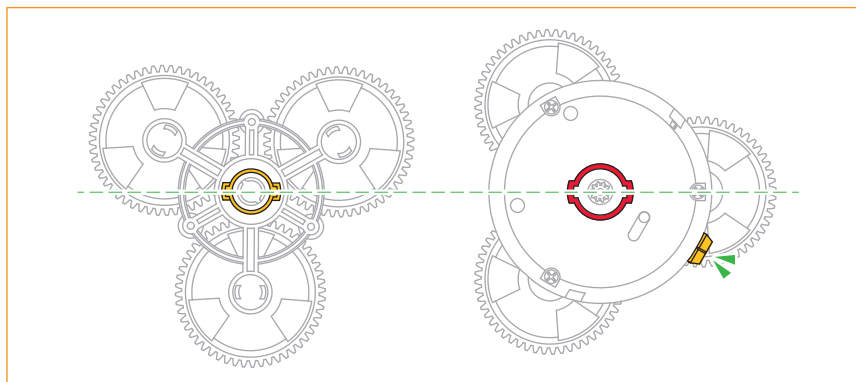
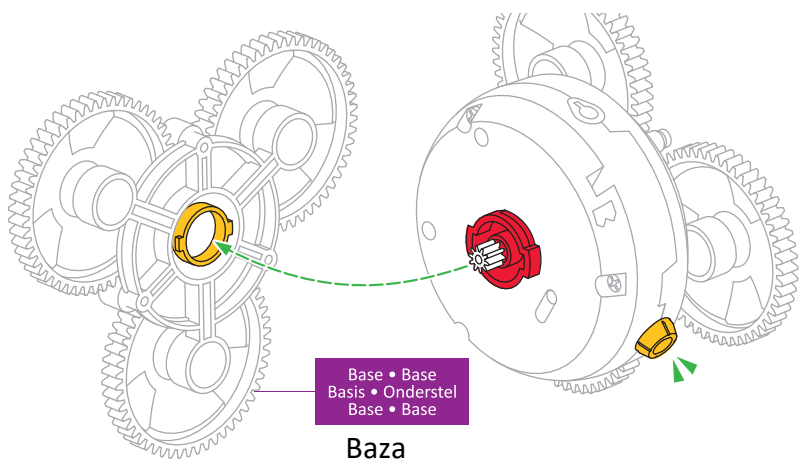

6

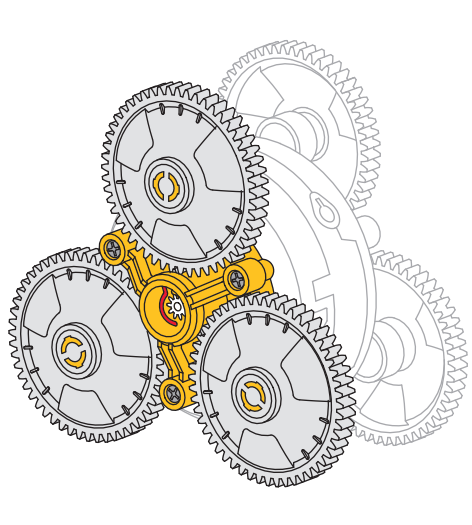
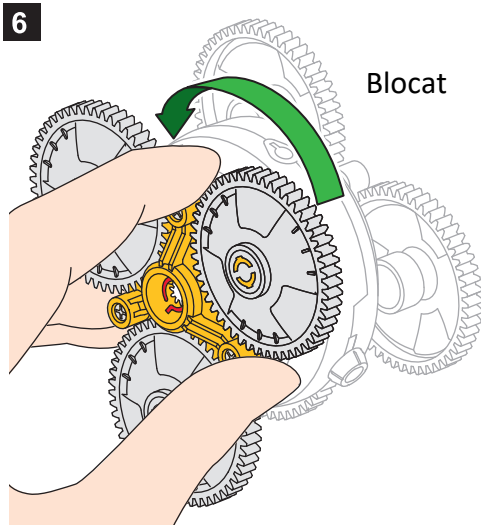

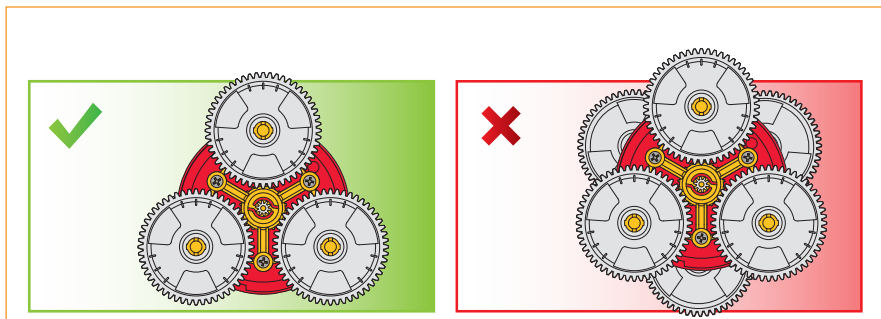

Cum functioneaza



Tineti giroscopul ca in imaginea de mai jos.

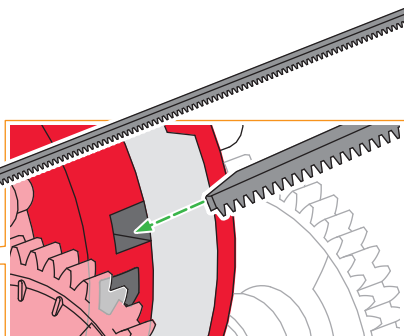
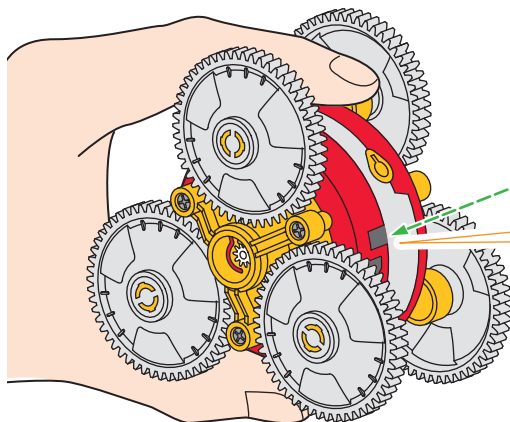

Trageti si impingeti cremaliera.

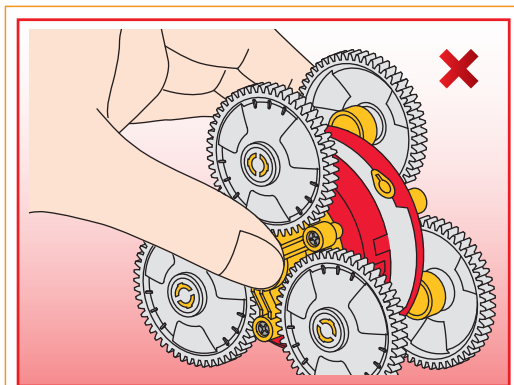

Nu tineti giroscopul de partile laterale!

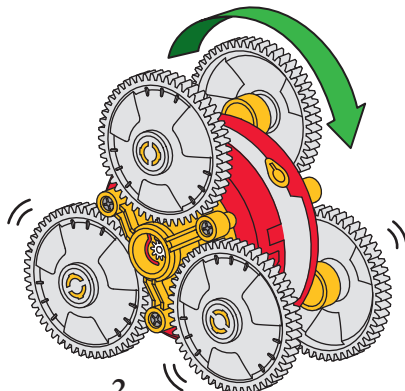

2
miscari inainte-inaoi

6 Montagne Russe



1

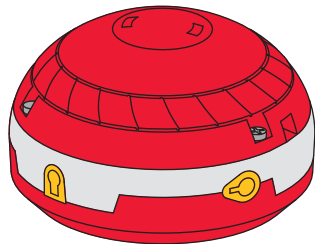
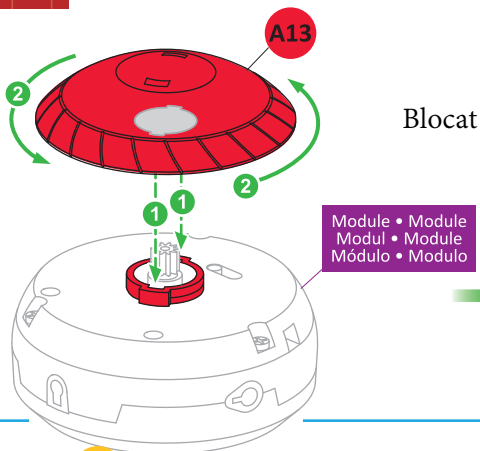

2

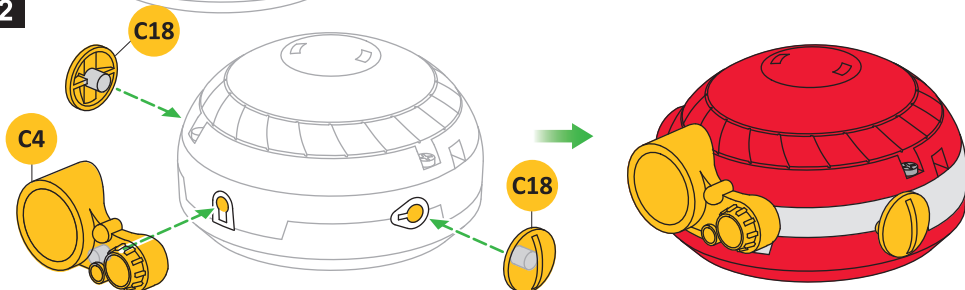

3 Cutia de viteze

Boîte de vitesse • Gearbox
Getriebe • Versnellingsbak
Caja de engranajes • Scatola di marcia

Patte gauche • Left leg
Linker Fuß • Linkerpoop
Pata izquierda • Gamba sinistra

Picior stang

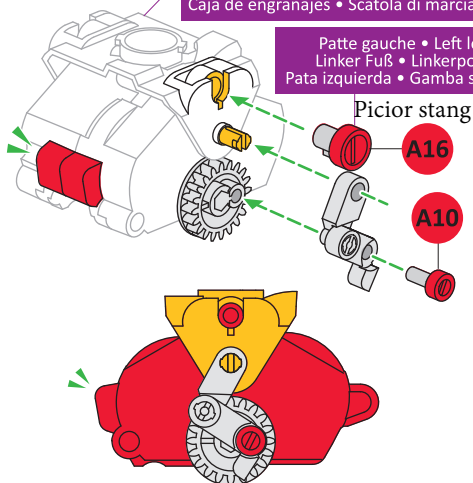

4

Patte droite • Right leg
Rechter Fuß • Rechterpoop
Pata derecha • Gamba destra

Picior drept

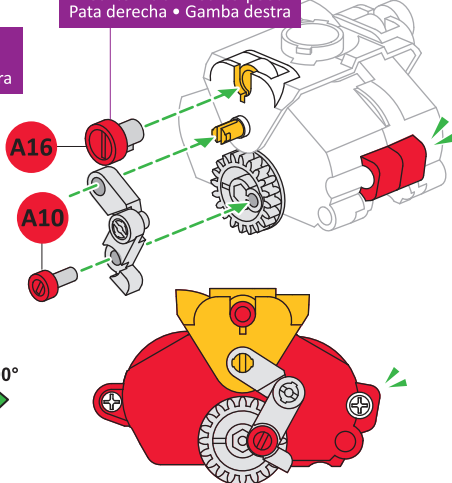

5

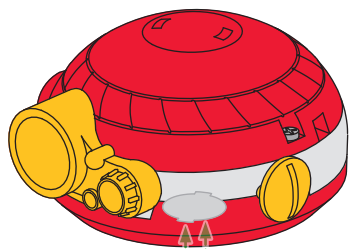

1

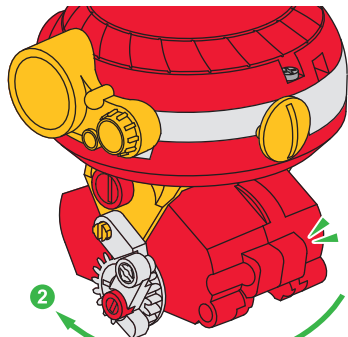
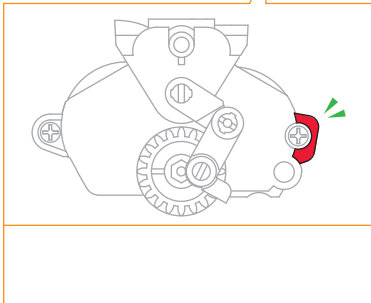
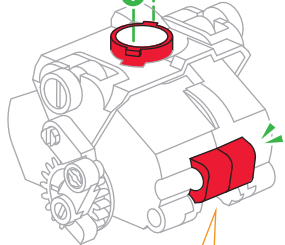

2

Blocat

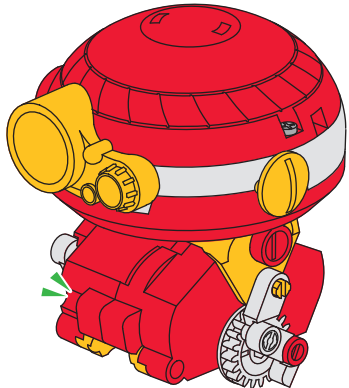

6

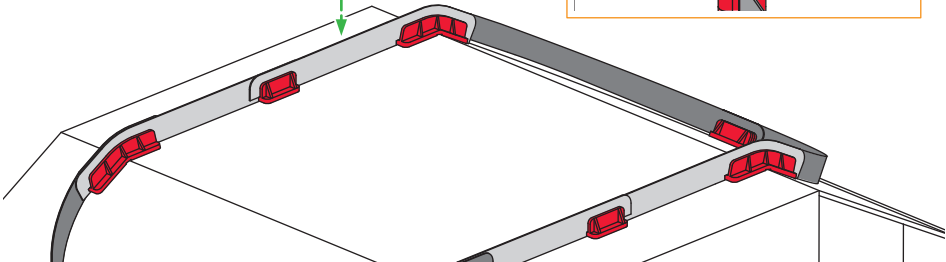
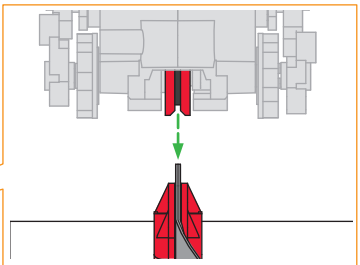
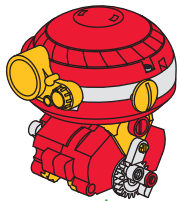

Cum functioneaza?



Tineti giroscopul ca in imaginea de mai jos.

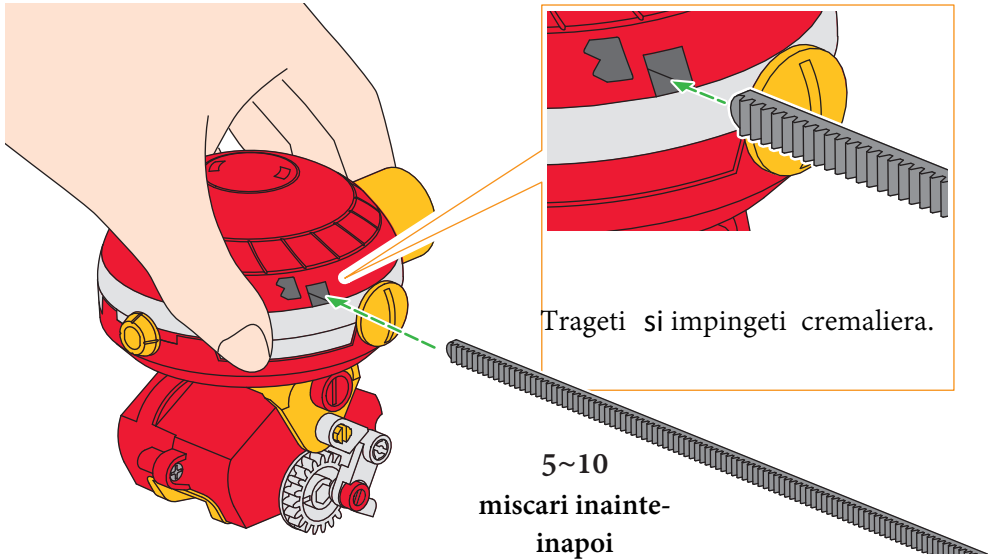

Mentineti robotul in echilibru pe pista.

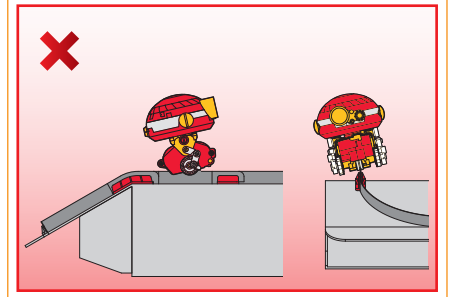
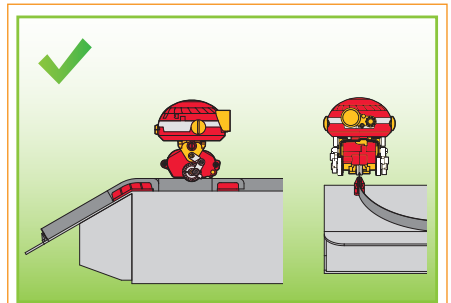

Rezolvarea problemelor

1. Daca giroscopul nu functioneaza corect:

Repetati pasii 1-9 (pagina 8-11). Este posibil ca un angrenaj sa nu fie pozitionat corect.

2. Daca Nastrusnicul Robbie cade :

Verificati cum a fost asamblata piesa B1 la pasul 6 – pagina 32.

3. Daca Motocicleta nu functioneaza corect:

Verificati pasul 5 – pagina 37.

4. Daca Montagne russe nu functioneaza corect:

Verificati cum a fost asamblata pista la psginile 22 - 25.

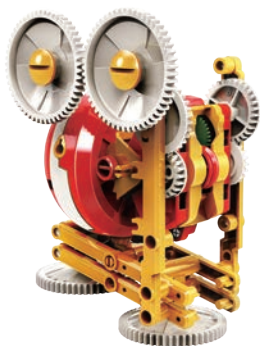





**RETROUVEZ-NOUS SUR
FIND US ON**

Buki France



ATENTIE! Numai pentru copiii cu varsta de 8 ani sau mai mari.
ATENTIE! Nu este potrivit pentru copiii sub 3 ani. Prezente elemente mici care pot fi inghitite. Pericol de sufocare.

ATENTIE! A se utiliza sub atenta supraveghere a unui adult. Prezente margini si muchii ascutite.

PASTRATI AMBALAJUL PENTRU REFERINTE ULTERIOARE! Culorile si continutul pot varia usor de la o jucarie la alta.

SUNT NECESARE: un cleste de taiat, un ciocan si o surubelnita cu cap in cruce, neincluse.

Se recomanda supravegherea unui adult!

Puteti asambla cate un singur model!

Photo Credits : iStock

22 rue du 33ème Mobiles - 72000 Le Mans - FRANCE

Tél: +33 1 46 65 09 92

E-mail : daniellevy@bezeqint.net

www.bukifrance.com

